

JADO VILLE SUBDIVISION II
PLAT CABINET A, SLIDE 757A

AUTUMN WOODS CONDOMINIUMS
PLAT CABINET B, SLIDE 848

LOT 4887

LOT 4885

BRODY DRIVE (60')

LOT 4886

JADO VILLE SUBDIVISION II
PLAT CABINET A, SLIDE 757A

STREET DEDICATION PLAT OF EXTENSION OF KRISTINA DRIVE

SECTION 27, TOWN 4, RANGE 14, CITY OF BELLEFONTAINE
LAKE TOWNSHIP, LOGAN COUNTY, OHIO

JOHN J. ZIESSLER AND DORIS A. ZIESSLER
ORIGINAL 103.13 ACRE TRACT
VOLUME 386, PAGE 705

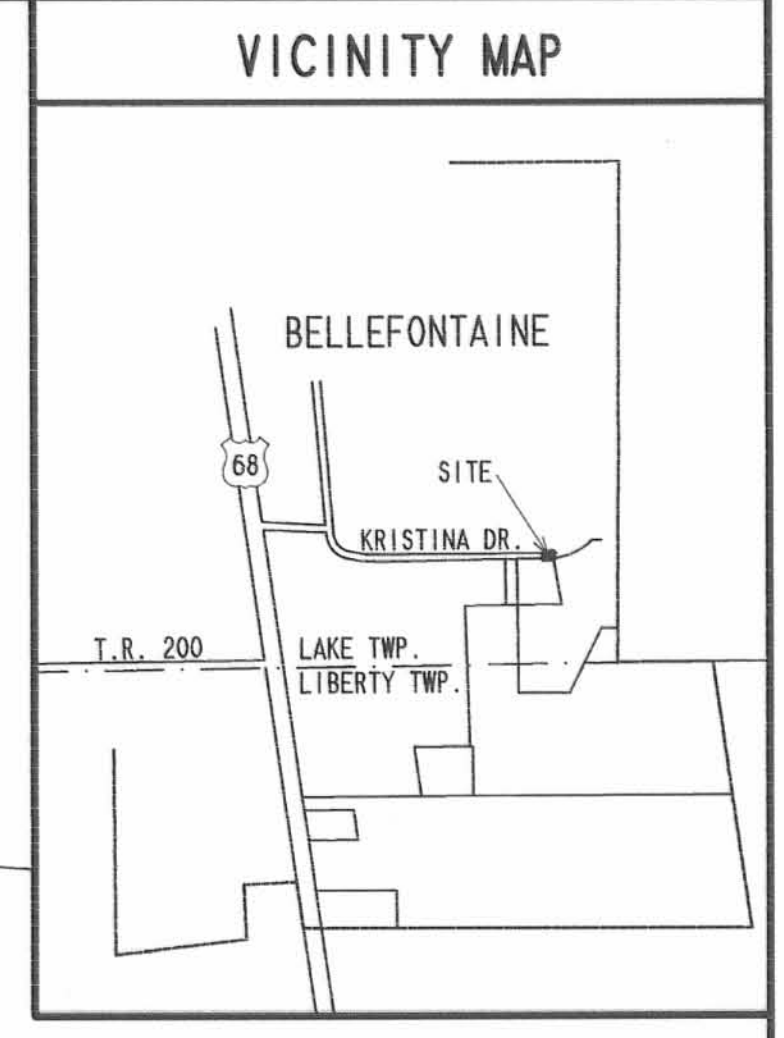

DEDICATION

KNOW BY ALL MEN THESE PRESENT THAT JOHN J. ZIESSLER AND DORIS ZIESSLER, OWNERS OF THE 0.080 ACRE OF LAND INDICATED ON THE ACCOMPANYING PLAT BY VIRTUE OF OFFICIAL RECORD 386, PAGE 705, OF THE LOGAN COUNTY RECORDS OF DEEDS HAVE AUTHORIZED THE DEDICATION OF THE EXTENSION OF KRISTINA DRIVE HEREON TO THE PUBLIC USE FOREVER.

WITNESS:

Don Stevens
DANNY A. WEBER
PRINTED NAME
DON STEVENS
PRINTED NAME

OWNERS:

John J. Ziessler
JOHN J. ZIESSLER
Doris A. Ziessler
DORIS A. ZIESSLER



JOHN J. ZIESSLER
AND DORIS A. ZIESSLER
ORIG. 103.13 ACRES
VOL. 386, PG. 705

CURVE	DELTA ANGLE	RADIUS	ARC	TANGENT	CHORD	CHORD BEARING
C 1	4°31'01"	250.00'	19.71'	9.86'	19.70'	S 86°39'40"E
C 2	4°31'01"	310.00'	24.44'	12.23'	24.43'	N 86°39'40"W

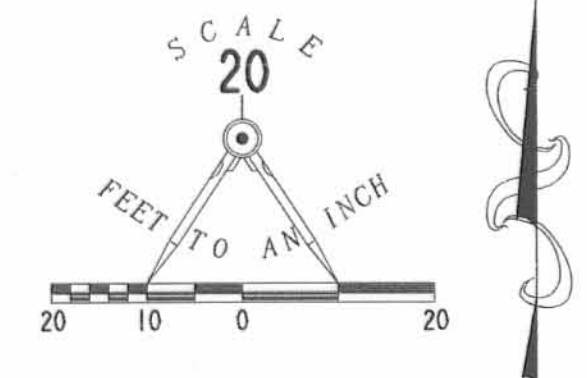

- LEGEND
- 5/8 INCH IRON ROD SET
 - 5/8 INCH IRON ROD FOUND
 - ⊙ MAG NAIL SET

NILO TWO LIMITED PARTNERSHIP
10.002 ACRES
O.R. 243, PG. 663

DESCRIPTION

LYING SECTION 27, TOWN 4, RANGE 14, CITY OF BELLEFONTAINE, LAKE TOWNSHIP, LOGAN COUNTY, OHIO.

BEING OUT OF THE JOHN J. ZIESSLER AND DORIS A. ZIESSLER ORIGINAL 103.13 ACRE TRACT AS DEEDED AND DESCRIBED IN VOLUME 386, PAGE 705 OF THE LOGAN COUNTY RECORDS OF DEEDS AND BEING MORE PARTICULARLY DESCRIBED AS FOLLOWS:

BEGINNING AT A 5/8 INCH IRON ROD FOUND ON THE SOUTHEAST CORNER OF LOT 4887 OF JADO VILLE SUBDIVISION II (PLAT CABINET A, SLIDE 757A) AND AUTUMN WOODS CONDOMINIUMS (PLAT CABINET B, SLIDE 848) AND ON THE NORTHEAST CORNER OF KRISTINA DRIVE.

THENCE, S 86°-24'-10" E, A DISTANCE OF 36.18 FEET TO A 5/8 INCH IRON ROD SET.

THENCE, WITH A CURVE TO THE LEFT HAVING A CENTRAL ANGLE OF 4°-31'-01", A RADIUS OF 250.00 FEET, AN ARC LENGTH OF 19.71', A CHORD BEARING S 86°-39'-40" E, A DISTANCE OF 19.70 FEET TO A 5/8 INCH IRON ROD SET.

THENCE, S 0°-55'-11" E, A DISTANCE OF 60.00 FEET TO A 5/8 INCH IRON ROD SET.

THENCE, WITH THE NORTH LINE OF NILO TWO LIMITED PARTNERSHIP 10.002 ACRE TRACT (O.R. 243, PG. 663), A CURVE TO THE RIGHT HAVING A CENTRAL ANGLE OF 4°-31'-01", A RADIUS 310.00 FEET, AN ARC LENGTH OF 24.44 FEET AND A CHORD BEARINGS N 86°-39'-40" W, A DISTANCE OF 24.43 FEET TO A MAG NAIL SET.

THENCE, WITH THE NORTH LINE OF THE SAID 10.002 ACRE TRACT AND LOT 4886, N 86°-24'-10" W, A DISTANCE OF 35.60 FEET TO A 5/8 INCH IRON ROD SET.

THENCE, WITH THE EAST LINE OF KRISTINA DRIVE (60 FEET WIDE), N 3°-02'-35" E, A DISTANCE OF 60.00 FEET TO THE POINT OF BEGINNING.

CONTAINING 0.080 ACRE.

THE BASIS FOR BEARINGS IS THE NORTH LINE OF LOT 4886, BEING N 86°-24'-10" W, AND ALL OTHER BEARINGS ARE FROM ANGLES AND DISTANCES MEASURED IN A FIELD SURVEY BY LEE SURVEYING AND MAPPING CO., INC. ON SEPTEMBER 11, 2003.

DESCRIPTION PREPARED BY: WILLIAM K. BRUCE, PROFESSIONAL SURVEYOR 7437, SEPT. 11, 2003.

STATE OF OHIO
COUNTY OF LOGAN

BEFORE ME A NOTARY PUBLIC IN AND FOR SAID STATE AND COUNTY PERSONALLY CAME JOHN J. ZIESSLER AND DORIS A. ZIESSLER WHO ACKNOWLEDGED THE SIGNING OF THE FOREGOING INSTRUMENT TO BE THEIR VOLUNTARY ACT AND DEED FOR THE USE AND PURPOSES THEREIN EXPRESSED THIS 10th DAY OF August, 2004, IN TESTIMONY WHEREOF, I HAVE HEREUNTO SUBSCRIBED MY NAME AND AFFIXED MY OFFICIAL SEAL THIS 10th DAY OF August, 2004.

Virginia M. Beasley
NOTARY PUBLIC

VIRGINIA M. BEASLEY
Notary Public, State of Ohio
My Commission Expires April 7, 2008

APPROVALS

THE WITHIN STREETS ARE HEREBY APPROVED AND ACCEPTED FOR PUBLIC MAINTENANCE BY ORDINANCE NO. 03-81 RECORDED IN CITY COUNCIL'S RECORD BOOK 03 ON THIS 9 DAY OF Dec 2003.

Robert C. Sutz Mayor, CITY OF BELLEFONTAINE
William R. Patterson President, BELLEFONTAINE CITY COUNCIL

APPROVED THIS 9 DAY OF December 2003
Timothy L. Norton BELLEFONTAINE CITY ENGINEER

APPROVED THIS 12th DAY OF Jan. 2004
Ed Wallace CHAIRMAN, BELLEFONTAINE CITY PLANNING COMMISSION

APPROVED THIS 9th DAY OF Jan. 2004
Vicki Yankow CLERK, BELLEFONTAINE CITY COUNCIL

PREAPPROVAL *Jon C. Kins* 9-18-03
PLAT CHECKED *Jon C. Kins* 8-11-04

TRANSFERRED THIS 11th DAY OF August 2004
Nickel E. Godwin AUDITOR, LOGAN COUNTY, OHIO

RECORDED IN PLAT CABINET B, SLIDE 90A RECEIVED FOR RECORD AT 2:58 PM THIS 11th DAY OF August 2004.

Linda S. Hanson RECORDER, LOGAN COUNTY, OHIO

SURVEYOR'S STATEMENT

THE ACCOMPANYING PLAT REPRESENTS STREET DEDICATION FOR THE EXTENSION OF KRISTINA DRIVE, SECTION 27, TOWN 4, AND RANGE 14, CITY OF BELLEFONTAINE, LAKE TOWNSHIP, LOGAN COUNTY, OHIO.

THE STREET HAS AN AREA OF 0.080 ACRE, ALL OF WHICH IS OUT OF THE JOHN J. ZIESSLER AND DORIS A. ZIESSLER ORIGINAL 103.13 ACRE TRACT AS DESCRIBED IN VOLUME 386, PAGE 705 OF THE LOGAN COUNTY RECORDS OF DEEDS.

ALL MEASUREMENTS ARE IN FEET AND DECIMALS OF A FOOT.

I HEREBY STATE THAT THIS PLAT REPRESENTS AN ACTUAL FIELD SURVEY, AND THAT ALL DIMENSIONAL DETAILS ARE CORRECT TO THE BEST OF MY KNOWLEDGE AND BELIEF, AND THAT THE MONUMENTS SHOWN HEREON HAVE BEEN PLACED.

William K. Bruce
WILLIAM K. BRUCE
PROFESSIONAL SURVEYOR 7437
SEPTEMBER 11, 2003



DEVELOPER

JOHN J. ZIESSLER
1700 TOWNSHIP ROAD 183
BELLEFONTAINE, OHIO 43311
(937) 592-0567

COPYRIGHT 2003 BY:
LEE SURVEYING & MAPPING CO., INC.
117 North Medriver Street
BELLEFONTAINE, OHIO 43311
(937) 593-7335
D 411 NILOSTAT KRISTINA.ASC L-2226-3