

**UTILITY OWNERS**

Electric- Logan County Power and Light Association, Inc.  
1587 County Road 32, North  
P.O. Box 279  
Bellefontaine, Ohio 43311-0279  
Phone: 937-592-5746

Gas- Dayton Power and Light Company  
Courthouse Plaza, SW  
P.O. Box 1247  
Dayton, Ohio 45401  
Phone: 937-331-4498

Telephone-Sprint/United Telephone  
125 North Main Street  
Sidney, Ohio 45365  
Phone: 937-498-5205

Sanitary- Indian Lake Sanitary Sewer District  
8100 State Route 708, South  
P.O. Box 535  
Russells Point, Ohio 43348  
Phone: 937-843-3328

Water- Village of Russells Point  
126 Sunnyside Avenue  
P.O. Box 356  
Russells Point, Ohio 43348  
Phone: 937-843-4626

**UNDERGROUND UTILITIES**  
THE LOCATION OF UNDERGROUND UTILITIES SHOWN ON THE PLANS ARE AS OBTAINED FROM THE OWNERS OF THE UTILITIES AS REQUIRED BY SECTION 153.64 O.R.C.

BOLT FD. at SE CORNER OF SW 1/4 at SW 1/4 OF SECTION 11  
P.I. STA. 7+543.638 Δ= 0°23'52" Lt.

R.R. SPIKE FD. @ SW CORNER OF SECTION 11 P.I. STA. 7+190.273

**TANGENT TABLE**

(1)	S 84°36'26"E	353.365m (1159.33')
(2)	S 85°00'09"E	595.656m (1954.25')
(3)	S 85°09'33"E	679.425m (2229.08')

NOTE: ALL DIMENSIONS, UNLESS OTHERWISE SPECIFIED ARE IN METERS, WITH ENGLISH EQUIVALENTS IN (FEET). IN CASE OF DISCREPANCY BETWEEN THE TWO, THE METRIC VALUES SHALL TAKE PRECEDENCE.

- CONVENTIONAL SIGNS**
- PROPOSED R/W ——— R/W
  - TEMPORARY R/W ——— T ——— T
  - EXISTING R/W ——— Ex. R/W
  - TOWNSHIP LINE ———
  - SECTION LINE ———
  - PROPERTY LINE ——— P
  - WORK LIMITS ——— W/L
  - EXISTING EDGE OF PAVEMENT ——— EX. EOP
  - RESIDENTIAL BLDG. □ OUT BUILDINGS
  - I.P.S. 5/8" IRON PIN WITH ODOT CAP SET ● P.K.S. P.K. NAIL SET
  - ⊗ RAILROAD SPIKE FOUND ⊙ I.P.F. IRON PIN OR PIPE FOUND

I hereby certify that this plat is a true delineation of a survey made by the Ohio Department of Transportation in 1992.

Mark L. Deam  
Registered Surveyor #7031

RECORDED  
LOGAN COUNTY  
Date: 1-4-99  
Book: 1  
Page: 103

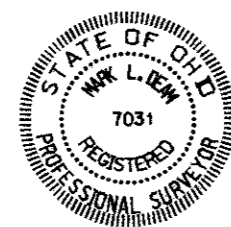

BLOOMFIELD TWP. SECTION 11 T7S R8E

WASHINGTON TWP. SECTION 11 T7S R8E

⑥ WILLIAM J. BEELMAN, JR. TRUSTEE  
64.7497 ha (160.00 ac.)  
O.R. Vol. 263, Pg. 465

⑤ PAUL WAMMES TRUST  
59.0841 ha (146.00 ac.)  
Vol. 398, Pg. 592

BEGIN ACQUISITION STA. 7+820.000

END ACQUISITION STA. 24+660.000

END WORK STA. 24+642.493

R.R. SPIKE FD. @ SE CORNER OF SECTION 11 P.I. STA. 8+818.720

END ACQUISITION STA. 8+460.000

BEGIN WORK STA. 7+813.627

BEGIN WORK STA. 24+034.209

END WORK STA. 8+440.775

R.R. SPIKE FD. 0.008 m Rt. STA. 24+339.291  
S.R. 235 = P.I. STA. 8+139.295 S.R. 274  
Δ= 0°09'25" Lt.

BEGIN ACQUISITION STA. 24+020.000

WASHINGTON TWP. SECTION 14 T7S R8E

① MURRELL W. & KATHLEEN R. VANSKOY  
0.8094 ha (2.00 ac.)  
Vol. 380, Pg. 779

② JOHN W. & VICKI L. SINGER  
0.8094 ha (2.00 ac.)  
Vol. 392, Pg. 902

③ FLOYD L. DEVER  
0.5140 ha (1.27 ac.)  
Vol. 406, Pg. 925

④ CHRISTINA D. WRIGHT  
1.6552 ha (4.09 ac.)  
O.R. Vol. 146, Pg. 34

⑦ INDIAN LAKE SCHOOL DISTRICT  
23.6094 ha (58.34 ac.)  
Vol. 312, Pg. 503

⑧ HARRISON J. NORVIEL  
4.2168 ha (10.42 ac.)  
Vol. 360, Pg. 263

- ⓔ-1 20' sewer easement to Indian Lake School District (Vol. 318, Page 921)
- ⓔ-2 20' sewer and water easement to Indian Lake School District (O.R. 315, Page 393)
- ⓔ-3 10' gas easement to The Dayton Power and Light Company (Vol. 332, Page 270)

NOTE: EXISTING RIGHT OF WAY LOCATION AND WIDTH DETERMINED FROM:

Road Record Journal "W", Page 125, establishes 60 feet of right-of-way on S.R. 235. (1927)

State Highway plan: LOG-274-4.81 (1996)

Commissioner's Volume 6, Pages 23 and 24, establishes 50 feet minimum right-of-way on S.R. 274. (March 1981)

State Highway plan: LOG-274-(4.67-5.03) (1954)

**BASIS OF BEARINGS:**

ALL BEARINGS SHOWN ARE FOR PROJECT USE ONLY. BEARINGS SHOWN FOR THE CENTERLINES ARE TAKEN FROM STATE HIGHWAY PLAN: LOG-274-(4.67-5.03) (1954)

PLAN COMPLETED: August 3, 1998

REV	DATE	DESCRIPTION
Amy	12/14/98	add record data
Amy	9/29/98	Revised Work Limit Stations
Amy	9/4/98	updated topo Parcel 7

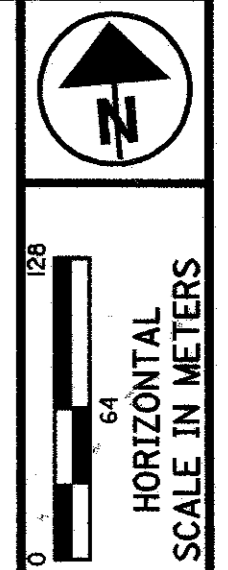

PTD NO. 18782

CENTERLINE PLAT AND PROPERTY MAP

LOG-235 / 274-23.641 / 8.095

1 / 12

13  
48

**TOTAL NUMBER OF :**

8 OWNERSHIPS            0 OWNERSHIPS WITH STRUCTURES INVOLVED  
 0 TOTAL TAKES            0 OWNERSHIPS WITH "P" ITEMS

NET RESIDUE = RECORD AREA - TOTAL PRO - NET TAKE

All areas shown in hectares with acres in parentheses.  
 0.4047 hectare = 1.000 acre; 1.0000 hectare = 2.471 acres

**GRANTEE:**

ALL RIGHT OF WAY ACQUIRED IN THE NAME OF  
 STATE OF OHIO UNLESS OTHERWISE SHOWN.



PARCEL NO.	OWNER	SHEET NO.	OWNERS RECORD		AUDITOR'S PARCEL	RECORD AREA(AC.)	TOTAL P.R.O.	GROSS TAKE	P.R.O. IN TAKE	NET TAKE	STRUC-TURE	NET RESIDUE		TYPE FUND	REMARKS AND PERSONALTY	AS ACQUIRED	
			BOOK	PAGE								LEFT	RIGHT			O.R.	PAGE
1	Murrell W. & Kathleen R. VANSCOY, H & W	4	VOL. 380	779	51-045-00-00-034-000	0.8094 (2.00)	0.0694 (0.171)	0.0429 (0.106)	0.0363 (0.090)	0.0066 (0.016)	N	0.7334 (1.813)		STATE		403	445
2	John W. SINGER & Vicki L. SINGER	4	VOL. 392	902	51-045-00-00-033-000	0.8094 (2.00)	0.0694 (0.171)	0.0968 (0.239)	0.0694 (0.171)	0.0274 (0.068)		0.7126 (1.761)				403	449
2T	Did not use																
3	Floyd L. DEVER	4 & 5	VOL. 406	925	51-045-00-00-032-000	0.5140 (1.27)	0.0418 (0.103)	0.0594 (0.147)	0.0418 (0.103)	0.0176 (0.044)		0.4546 (1.123)			P = TWO WOOD POSTS	403	443
4	Christina D. WRIGHT	5,6 & 11	O.R. 146	34	51-045-00-00-032-001	1.6552 (4.09)	0.4727 (1.168)	0.2249 (0.556)	0.1682 (0.416)	0.0567 (0.140)		1.1258 (2.782)			0.0098 ha (0.024 Ac.) encumb. by easement Vol. 318, Pg. 921	403	447
4T	Did not use																
5	Paul WAMMES Trust	6-8 & 10-13	VOL. 398	592	51-045-00-00-012-000	59.0841 (146.00)	2.2087 (5.458)	1.3841 (3.420)	1.0597 (2.619)	0.3244 (0.801)		5.8435 (14.440)	50.7075 (125.301)		*** see below *** see below	403	451
5T		6-7						0.0400 (0.099)	0.0000 (0.000)	0.0400 (0.099)				To Grade and Seed			
5T-1	Did not use	6-7															
5T-2		10						0.0131 (0.032)	0.0000 (0.000)	0.0131 (0.032)				To Grade and Seed			
5T-3		6,11						0.0040 (0.010)	0.0000 (0.000)	0.0040 (0.010)				To Grade and Seed			
6	William J. BEELMAN, Jr. Trustee	9 & 10	O.R. 263	465	51-045-00-00-014-000	64.7497 (160.00)	1.2420 (3.069)	0.3311 (0.818)	0.2834 (0.700)	0.0477 (0.118)		63.4600 (156.813)			0.3311 ha (0.818 Ac.) in Auditor's No. 51-045-00-00-014-000	403	441
6T	Did not use																

FEDERAL PROJECT NO.

PID NO. 18782

STATE JOB NO.

SUMMARY OF ADDITIONAL RIGHT OF WAY

LOG-235 / 274-23.641 / 8.095

NOTE: ALL TEMPORARY PARCELS TO BE OF 4 MONTHS DURATION

UNDER NO CIRCUMSTANCES ARE TEMPORARY EASEMENTS ACQUIRED FOR THE PURPOSE OF STRUCTURE REMOVAL TO BE USED FOR STORAGE OF MATERIAL OR EQUIPMENT BY THE CONTRACTOR. UPON COMPLETION OF THE WORK REQUIRED FOR SUCH REMOVAL AND SUBSEQUENT RECLAMATION, THE EASEMENT SHALL BE VACATED IMMEDIATELY.

\* DENOTES RIGHT OF WAY ENCROACHMENT

\*\*\* breakdown of acreage in Parcel 5:  
 (unknown Ac. encumb. by easement Vol. 407, Pg. 349)  
 (0.0957 ha, 0.237 Ac. encumb. by easement Vol. 332, Pg. 270)  
 (0.0210 ha, 0.052 Ac. encumb. by easement O.R. 315, Pg. 393)

REV	DATE	DESCRIPTION
		PLAN COMPLETED August 3, 1998
Amy	12/14/98	rem. #013 (5), 015 (6)
Amy	9/29/98	Del. 2T, 4T & 6T
Amy	9/8/98	Del. 5T-1

2/12

14  
48

**TOTAL NUMBER OF :**

8 OWNERSHIPS                      0 OWNERSHIPS WITH STRUCTURES INVOLVED  
 0 TOTAL TAKES                    0 OWNERSHIPS WITH "P" ITEMS

**NET RESIDUE = RECORD AREA - TOTAL PRO - NET TAKE**

All areas shown in hectares with acres in parentheses.  
 0.4047 hectare = 1.000 acre; 1.0000 hectare = 2.471 acres

**GRANTEE:**

ALL RIGHT OF WAY ACQUIRED IN THE NAME OF  
 STATE OF OHIO UNLESS OTHERWISE SHOWN.

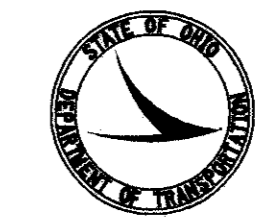

**metric  
units**

PARCEL NO.	OWNER	SHEET NO.	OWNERS RECORD		AUDITOR'S PARCEL	RECORD AREA(AC.)	TOTAL P.R.O.	GROSS TAKE	P.R.O. IN TAKE	NET TAKE	STRUC-TURE	NET RESIDUE		TYPE FUND	REMARKS AND PERSONALTY	AS ACQUIRED	
			BOOK	PAGE								LEFT	RIGHT			BOOK	PAGE
7T	Indian Lake School District	6,11	VOL. 312	503	51-045-00-00-039-000	23.6094 (58.340)	0.9856 (2.435)	0.0195 (0.048)	0.0000 (0.000)	0.0195 (0.048)	N	22.6238 (55.905)	STATE	To Grade and Seed			
7T-1		12						0.0223 (0.055)	0.0000 (0.000)	0.0223 (0.055)				Correct Drainage, Grade and Seed			
7T-2		12 & 13						0.0916 (0.226)	0.0000 (0.000)	0.0916 (0.226)				Correct Drainage, Grade and Seed			
7T-3		13						0.0002 (0.001)	0.0000 (0.000)	0.0002 (0.001)				To Construct Drive Approach and To Grade and Seed			
8T	Harrison J. NORVIEL	13	VOL. 360	263	51-045-00-00-040-000	4.2168 (10.42)	0.1048 (0.259)	0.0069 (0.017)	0.0000 (0.000)	0.0069 (0.017)		4.1120 (10.161)		To Construct Drive Approach and To Grade and Seed			

FEDERAL PROJECT NO.

PID NO. 18782

STATE JOB NO.

SUMMARY OF ADDITIONAL RIGHT OF WAY

LOG-235 / 274-23.641 / 8.095

\* DENOTES RIGHT OF WAY ENCROACHMENT

NOTE: ALL TEMPORARY PARCELS TO BE OF 4 MONTHS DURATION

UNDER NO CIRCUMSTANCES ARE TEMPORARY EASEMENTS ACQUIRED FOR THE PURPOSE OF STRUCTURE REMOVAL TO BE USED FOR STORAGE OF MATERIAL OR EQUIPMENT BY THE CONTRACTOR. UPON COMPLETION OF THE WORK REQUIRED FOR SUCH REMOVAL AND SUBSEQUENT RECLAMATION, THE EASEMENT SHALL BE VACATED IMMEDIATELY.

PLAN COMPLETED: August 3, 1998

REV	DATE	DESCRIPTION
Amy	9/4/98	Add Temp.'s - Parcel 7

3 / 12

15 / 48

TANGENT TABLE

- (1) N 81°47'49"W 9.144 m (30.00')
- (2) S 81°50'19"E 12.500 m (41.01')
- (3) S 81°52'56"E 13.000 m (42.65')

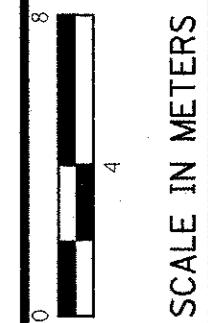
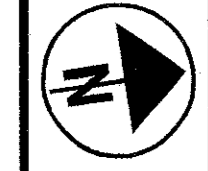

WASHINGTON TOWNSHIP SECTION 14 T7S R8E

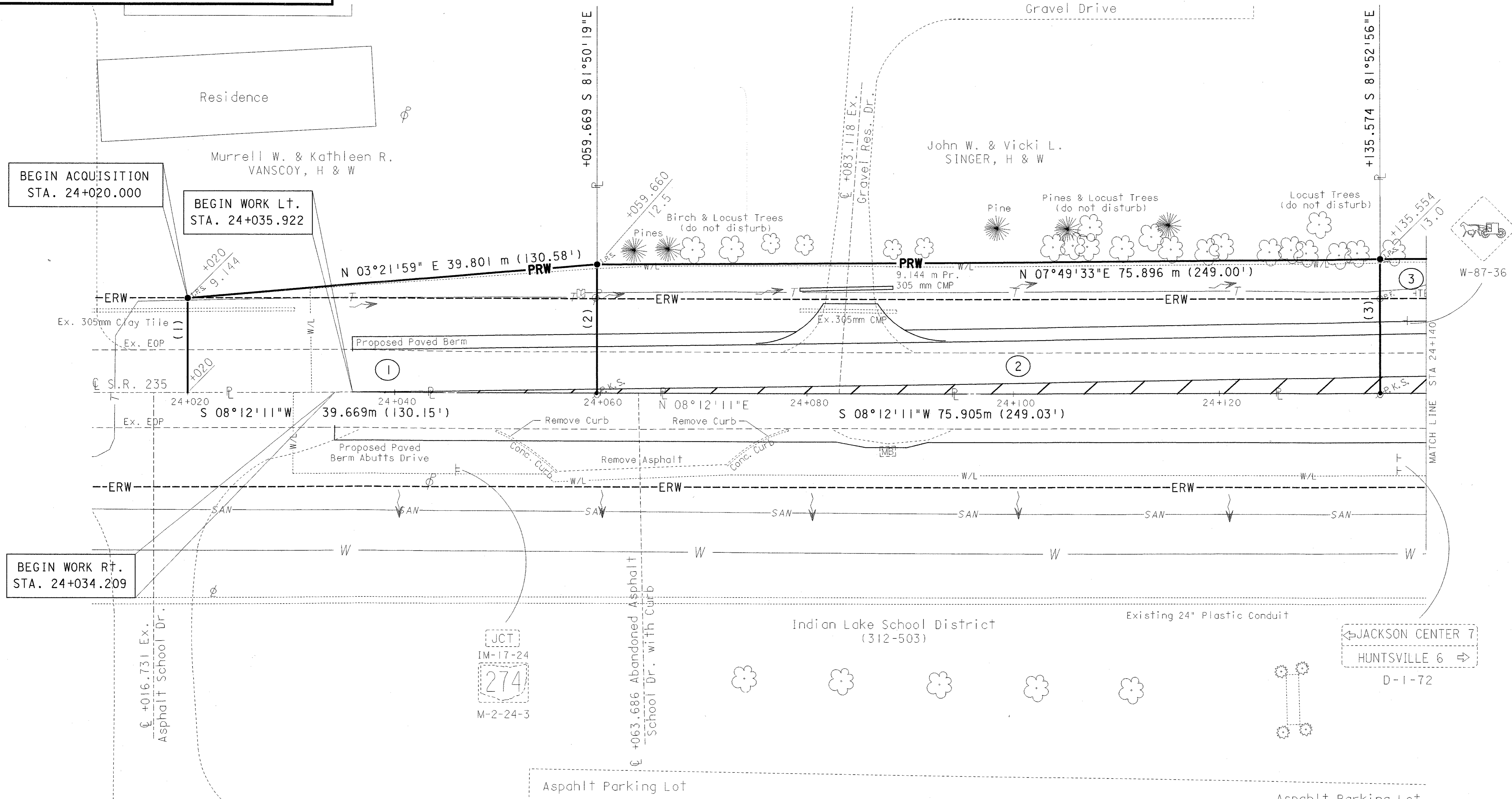

BEGIN ACQUISITION  
STA. 24+020.000

BEGIN WORK Lt.  
STA. 24+035.922

BEGIN WORK Rt.  
STA. 24+034.209

PID NO.  
**18782**

**DETAIL & RIGHT OF WAY PLAN**  
**S.R. 235 STA. 24+000 TO STA. 24+140**

LOG-235/274-23.641/8.095

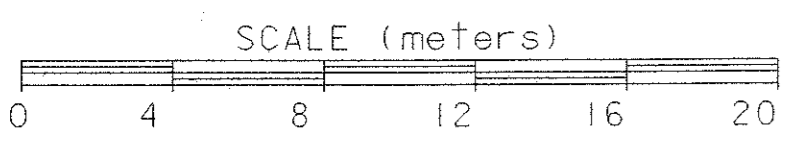

PLAN COMPLETED August 3, 1998

REV	DATE	DESCRIPTION
Amy	9/29/98	Del. 2T, Rev. Work Limits

TANGENT TABLE  
 (1) N 81°50'45"W 13.000 m (42.65')

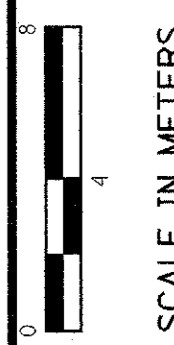

WASHINGTON TOWNSHIP SECTION 14 T7S R8E

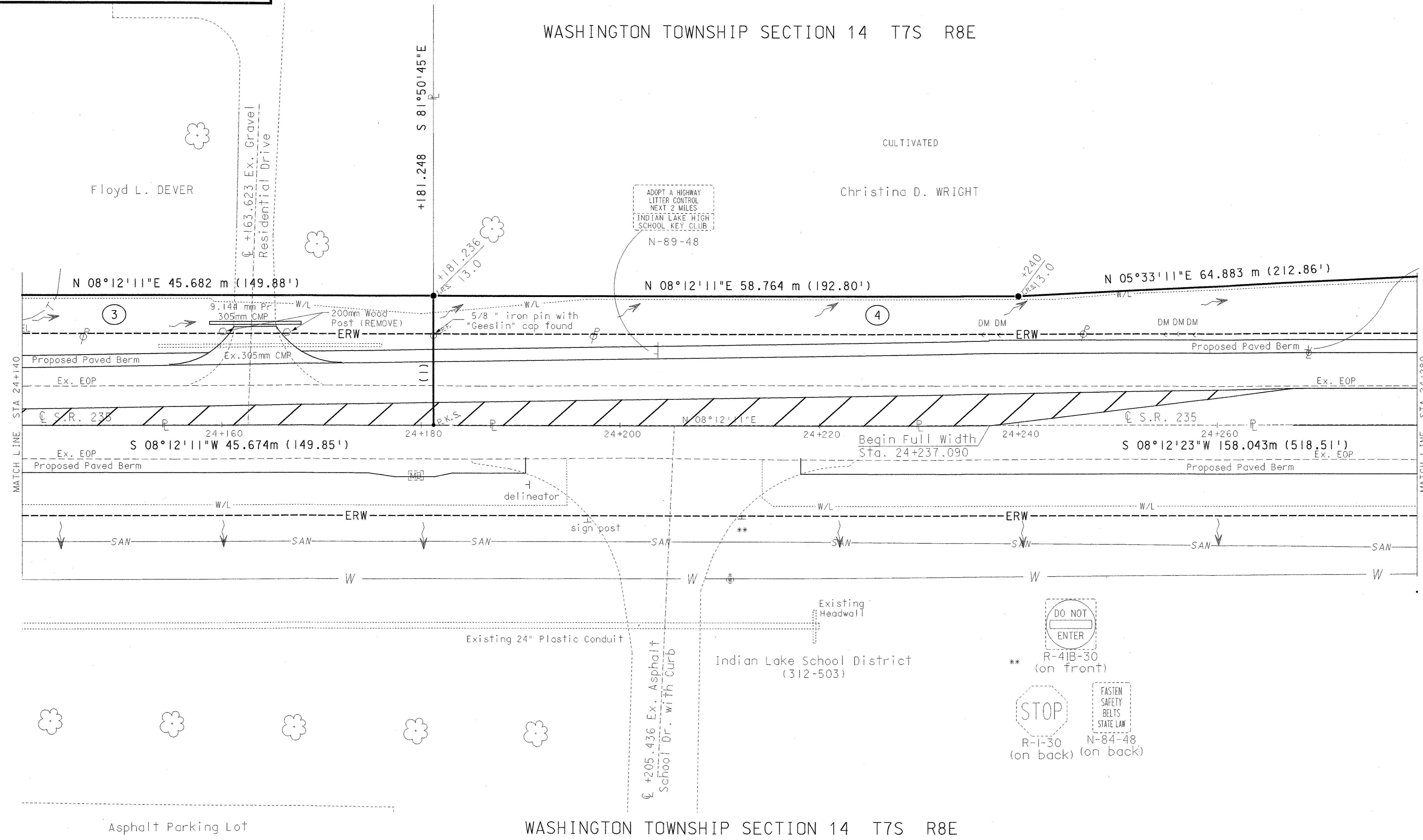

SOUTH  
 M-38-24  
 235  
 M-2-24-3

PID NO.  
**18782**

**DETAIL & RIGHT OF WAY PLAN**  
**S.R. 235 STA. 24+140 TO STA. 24+280**

LOG-235/274-23.641/8.095

5/14

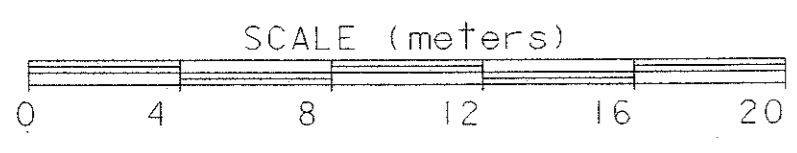

WASHINGTON TOWNSHIP SECTION 14 T7S R8E

PLAN COMPLETED: August 3, 1998

REV	DATE	DESCRIPTION
Amy	8/29/98	Del. 4T, Rev. Work Limits

TANGENT TABLE

(1)	S 48°01'39"W	4.684 m (15.37')
(2)	S 08°12'11"W	27.364 m (89.78')
(3)	N 81°47'49"W	7.656 m (25.12')
(4)	N 50°26'23"E	11.390 m (37.37')

WASHINGTON TOWNSHIP SECTION 14 T7S R8E

WASHINGTON TOWNSHIP SECTION 11 T7S R8E

CULTIVATED

Christina D. WRIGHT

Paul WAMMES Trust

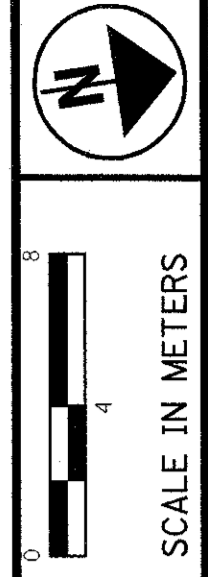
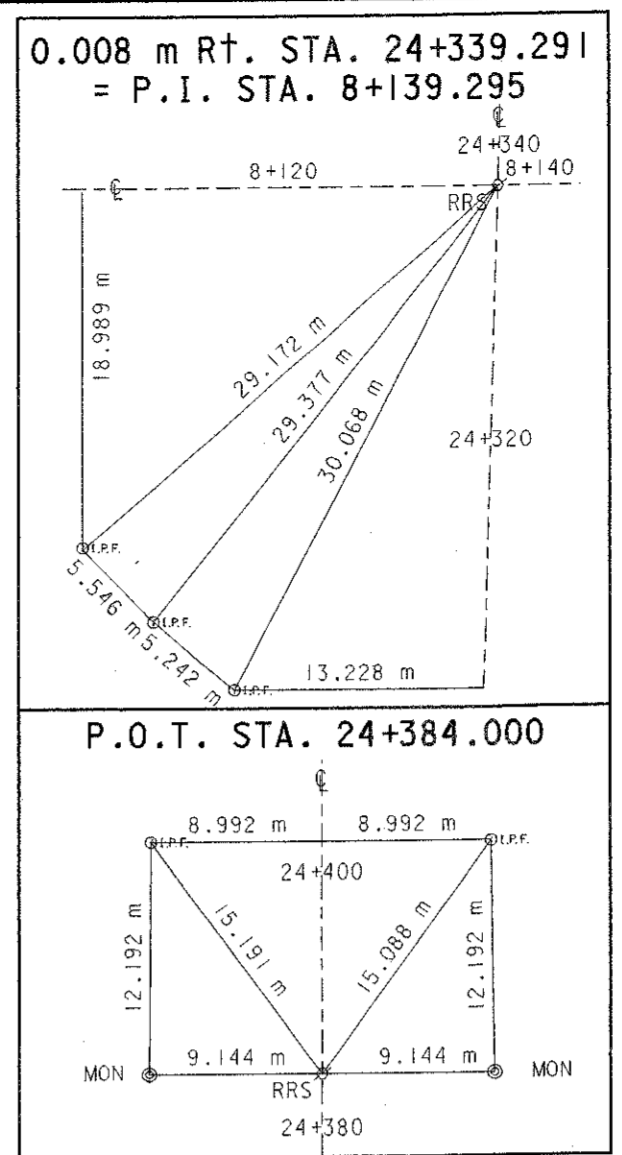
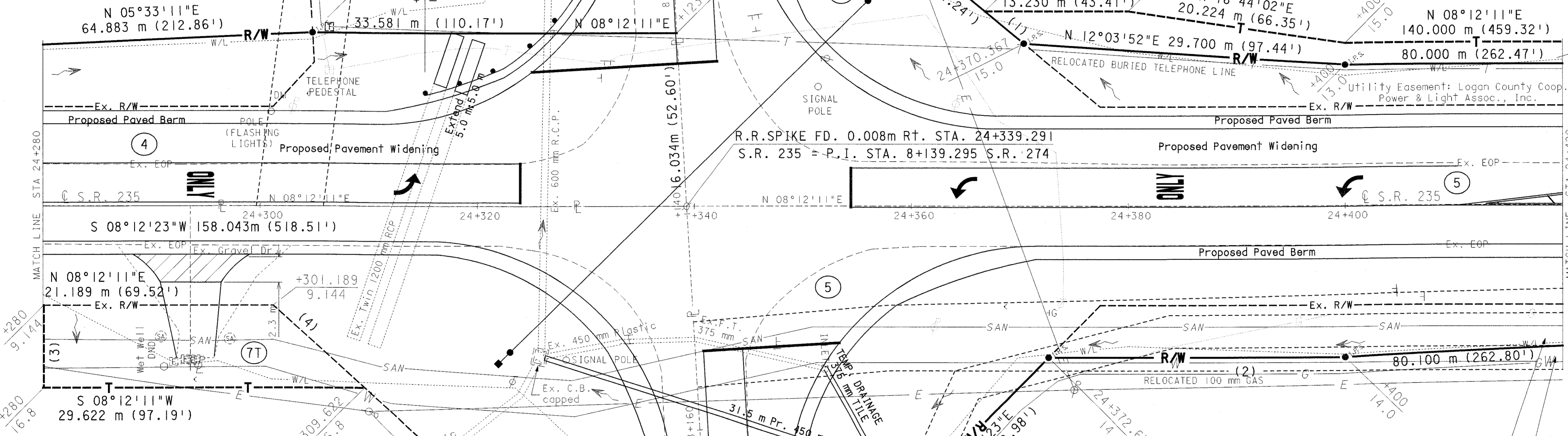

PID NO.  
**18782**

**DETAIL & RIGHT OF WAY PLAN**  
**S.R. 235 STA. 24+280 TO STA. 24+420**

**LOG-235/274-23.641/8.095**

Indian Lake School District  
(312-503)

Paul WAMMES Trust

WASHINGTON TOWNSHIP SECTION 14 T7S R8E

WASHINGTON TOWNSHIP SECTION 11 T7S R8E

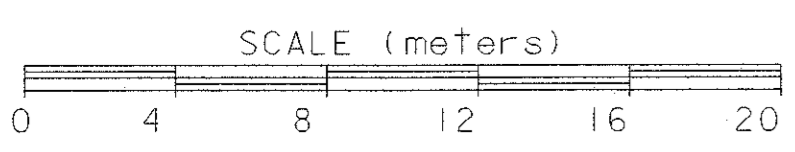

NOTES:  
SEE SHEET 14 OF 14 FOR SIGNING

**BENCHMARK**  
TOP OF RAILROAD SPIKE  
0.008 m Rt. STA. 24+339.291 @ 235  
= STA. 8+139.295 @ 274  
ELEVATION 301.737

PLAN COMPLETED: August 3, 1998		
REV	DATE	DESCRIPTION
Amy	12/14/98	change call out on 7T
Amy	9/29/98	Del. 4T & 5T-1

6 / 14  
16  
43

TANGENT TABLE  
 (1) S 81°47'49"E 2.857 m (9.37')

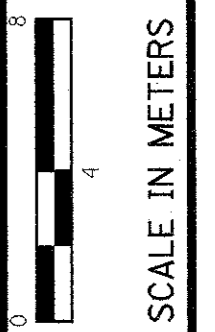
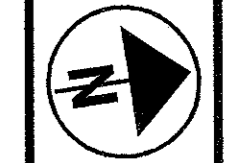

PID NO.  
**18782**

WASHINGTON TOWNSHIP SECTION 14 T7S R8E

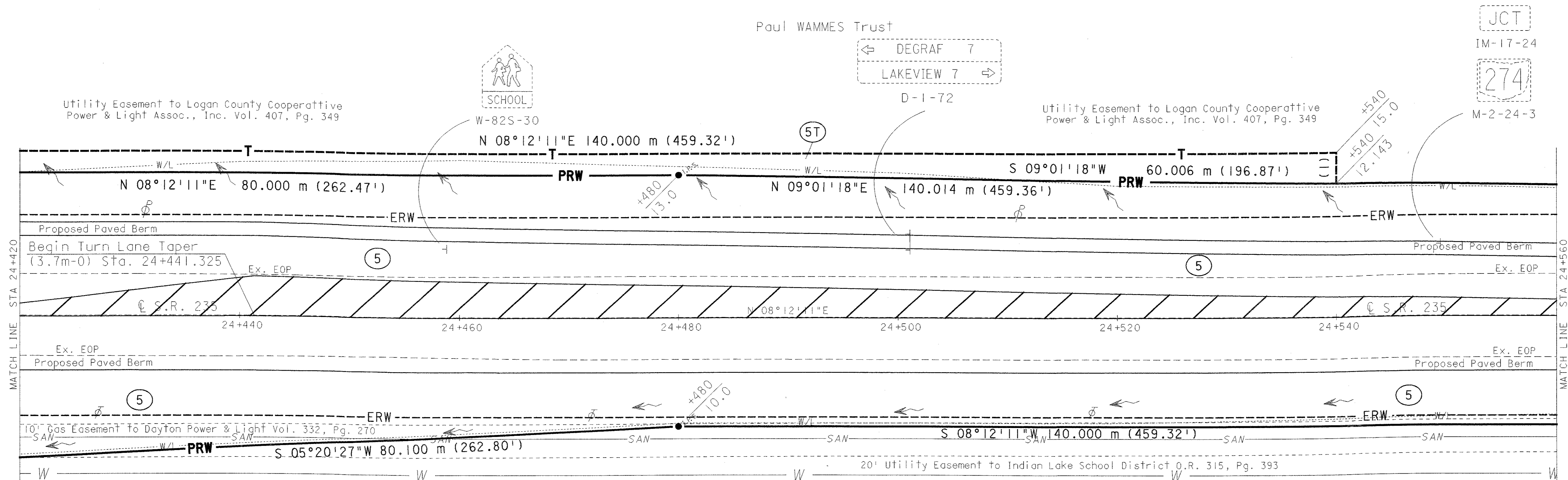

MATCH LINE STA 24+420

MATCH LINE STA 24+560

Paul WAMMES Trust

WASHINGTON TOWNSHIP SECTION 14 T7S R8E

DETAIL & RIGHT OF WAY PLAN  
 S.R. 235 STA. 24+420 TO STA. 24+560

LOG-235/274-23.641/8.095

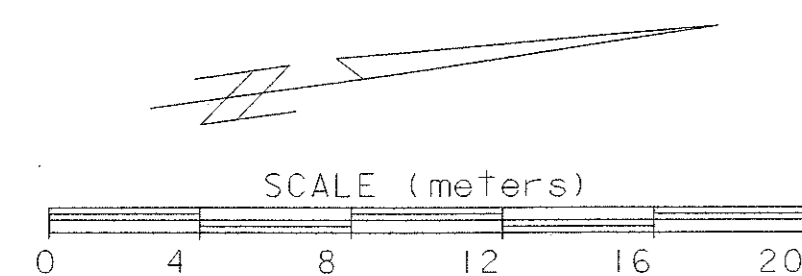

REV	DATE	DESCRIPTION

7 / 14

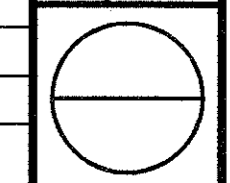

PLAN COMPLETED: August 3, 1998

REV DATE DESCRIPTION  
 Amy 9/29/98 Del. 5T-1

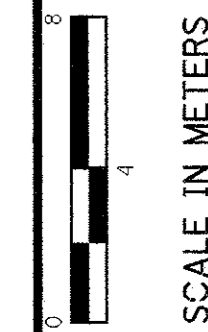
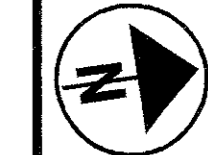

WASHINGTON TOWNSHIP SECTION 14 T7S R8E

PID NO.  
**18782**

**DETAIL & RIGHT OF WAY PLAN**  
**S.R. 235 STA. 24+560 TO STA. 24+700**

**LOG-235 / 274-23.641 / 8.095**

8 / 14

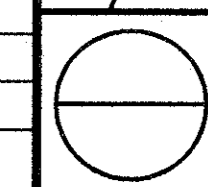

Utility Easement to Logan County Cooperative Power & Light Assoc., Inc. Vol. 407, Pg. 349

Utility Easement to Logan County Cooperative Power & Light Assoc., Inc. Vol. 407, Pg. 349

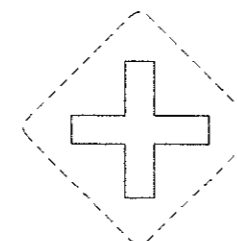

Paul WAMMES Trust

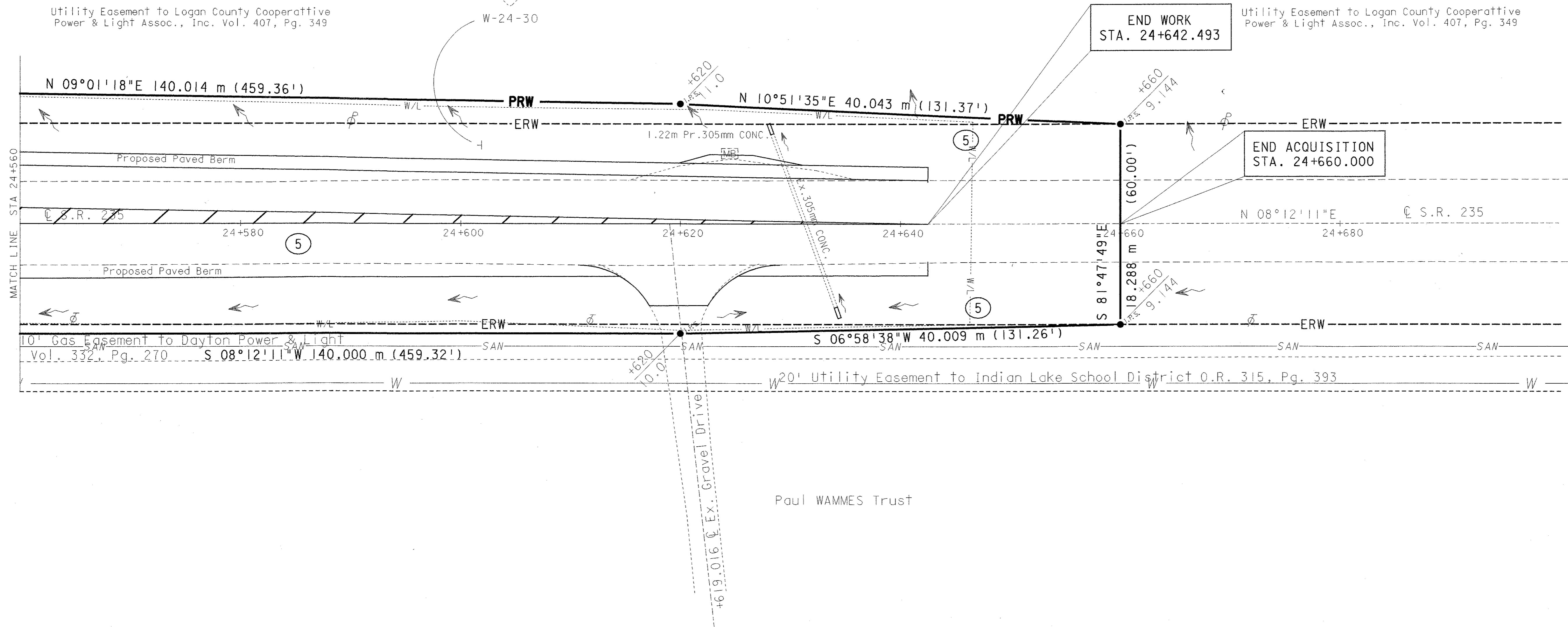

WASHINGTON TOWNSHIP SECTION 14 T7S R8E

Paul WAMMES Trust

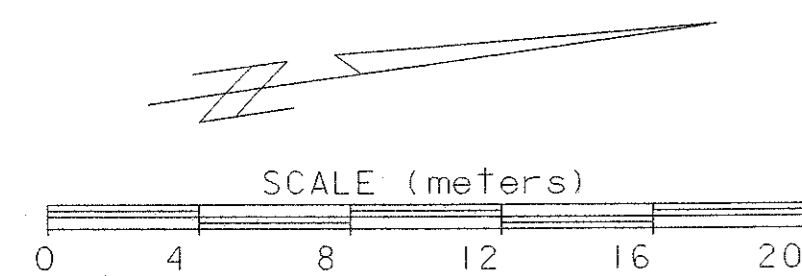

PLAN COMPLETED: August 3, 1998	
REV	DESCRIPTION
8	9/29/98 Rev. Work Limits



FOR ESTIMATED QUANTITIES SEE SHEET  
FOR DRIVE DETAILS SEE SHEET

WASHINGTON TOWNSHIP SECTION 11 T7S R8E

William J. BEELMAN, Jr. TRUSTEE

\* SPLICE PROPOSED GUARDRAIL TO EXISTING GUARDRAIL

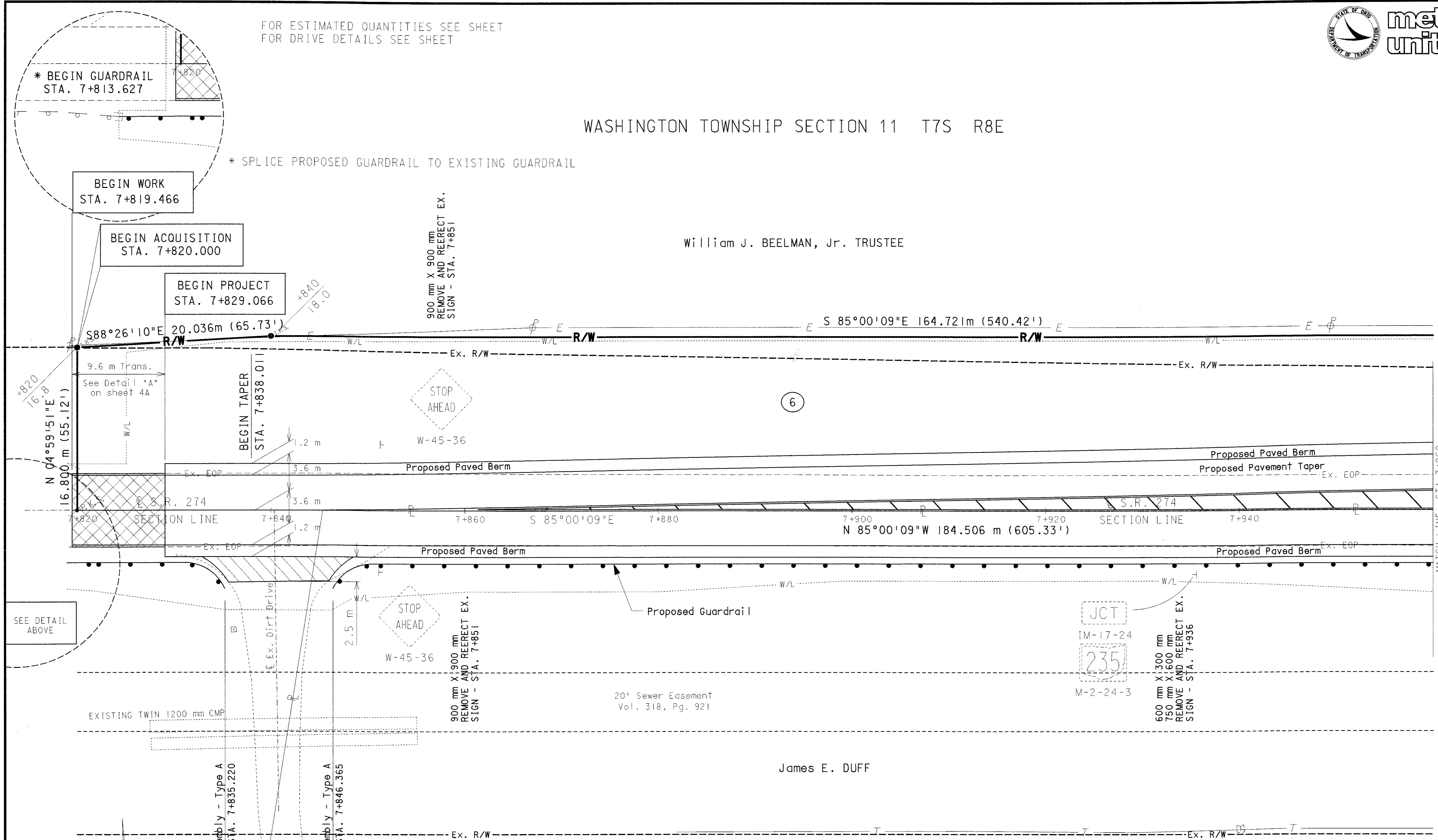

PID NO.  
**18782**

**DETAIL & RIGHT OF WAY PLAN**  
**S.R. 274 STA. 7+820 TO STA. 7+960**

20' Sewer Easement  
Vol. 318, Pg. 921

James E. DUFF

**LOG-235/274-23.641/8.095**

SEE DETAIL ABOVE

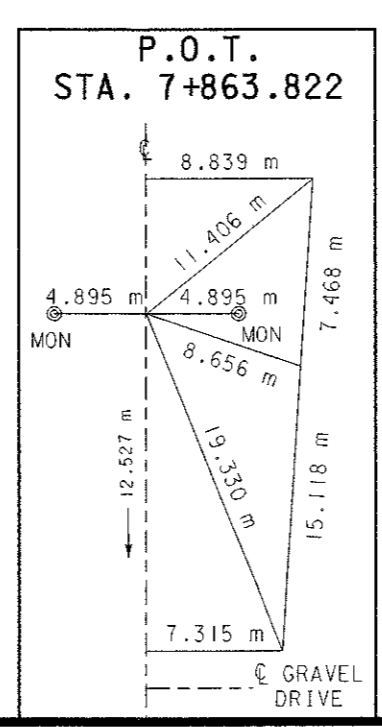
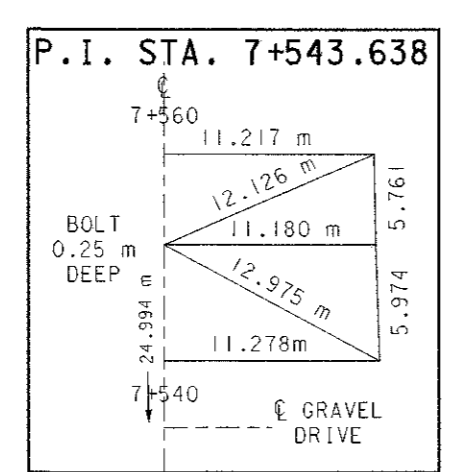

**BENCHMARK #51**  
□ CUT ON NW CORNER OF  
E. CONCRETE ABUT. BR-0468  
6.096 m LT. STA. 7+799.680  
ELEVATION 302.102

**BENCHMARK #52**  
RAILROAD SPIKE  
IN POWER POLE  
16.002 m LT. STA. 7+894.015  
ELEVATION 298.798

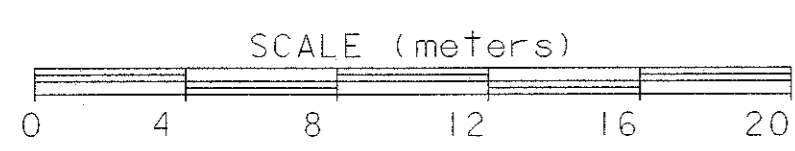

REV	DATE	DESCRIPTION
Amy	9/30/98	Del. 6T, Rev. Work Limits

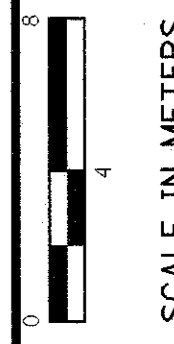

TANGENT TABLE

(1)	S 05°40'51"W	2.000 m (6.56')
(2)	S 04°59'51"W	2.000 m (6.56')

FOR ESTIMATED QUANTITIES SEE SHEET  
FOR DRIVE DETAILS SEE SHEET

WASHINGTON TOWNSHIP SECTION 11 T7S R8E

William J. BEELMAN, Jr. TRUSTEE

Paul WAMMES Trust

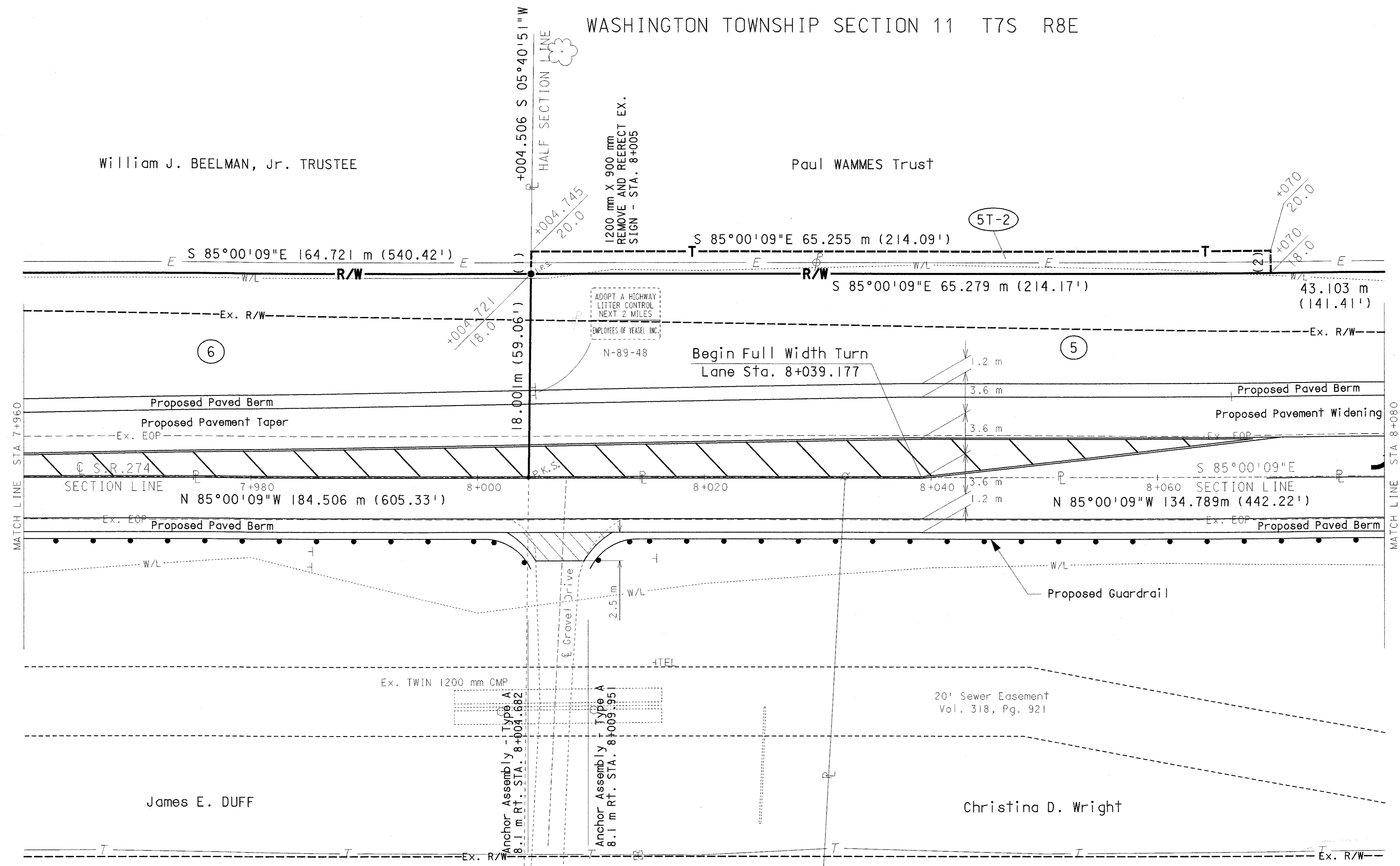

WASHINGTON TOWNSHIP SECTION 14 T7S R8E

PID NO.  
**18782**

**DETAIL & RIGHT OF WAY PLAN**  
**S.R. 274 STA. 7+960 TO STA. 8+080**

**LOG-235/274-23.641/8.095**

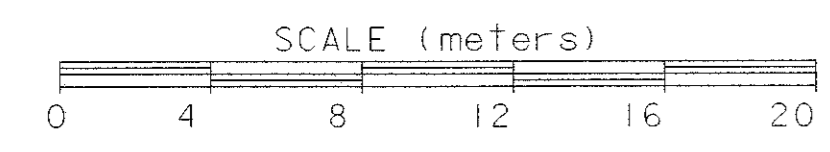

PLAN COMPLETED: August 3, 1998

REV	DATE	DESCRIPTION
Amy	9/30/98	Del. 6T, Rev. Work Limits

10/14  
20/43

TANGENT TABLE

- (1) N 37°24'23"W 1.351 m (4.43')
- (2) S 04°50'27"W 1.664 m (5.46')

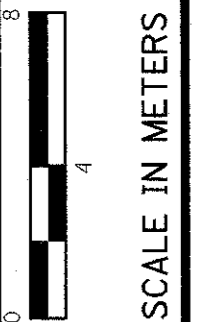
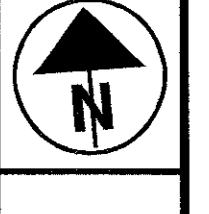

WASHINGTON TOWNSHIP SECTION 11 T7S R8E

Paul WAMMES Trust

PID NO. 18782

DETAIL & RIGHT OF WAY PLAN S.R. 274 STA. 8+080 TO STA. 8+220

LOG-235/274-23.641/8.095

PLAN COMPLETED August 3, 1998  
11 / 14  
21 / 43

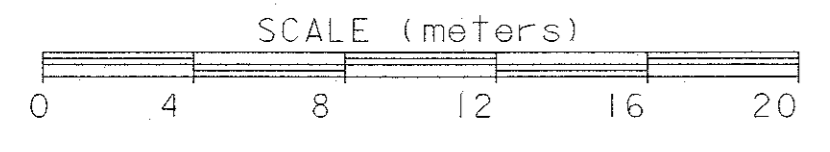
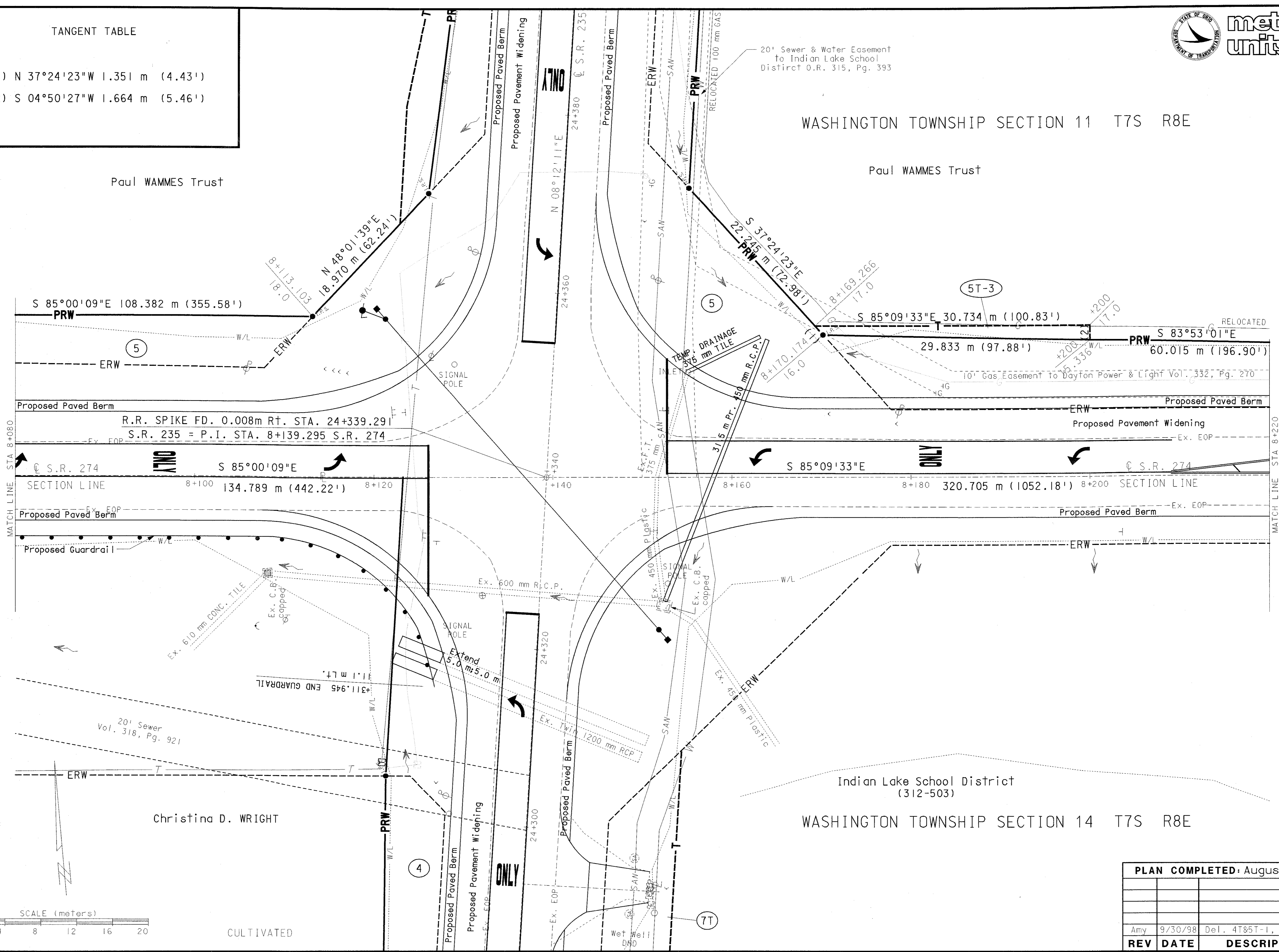

REV	DATE	DESCRIPTION
Amy	9/30/98	Del. 4T&5T-1, Rev. 5&5T

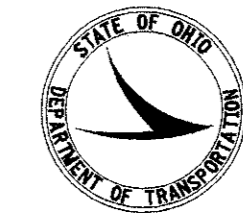

metric units



SCALE IN METERS

WASHINGTON TOWNSHIP SECTION 11 T7S R8E

Paul WAMMES Trust

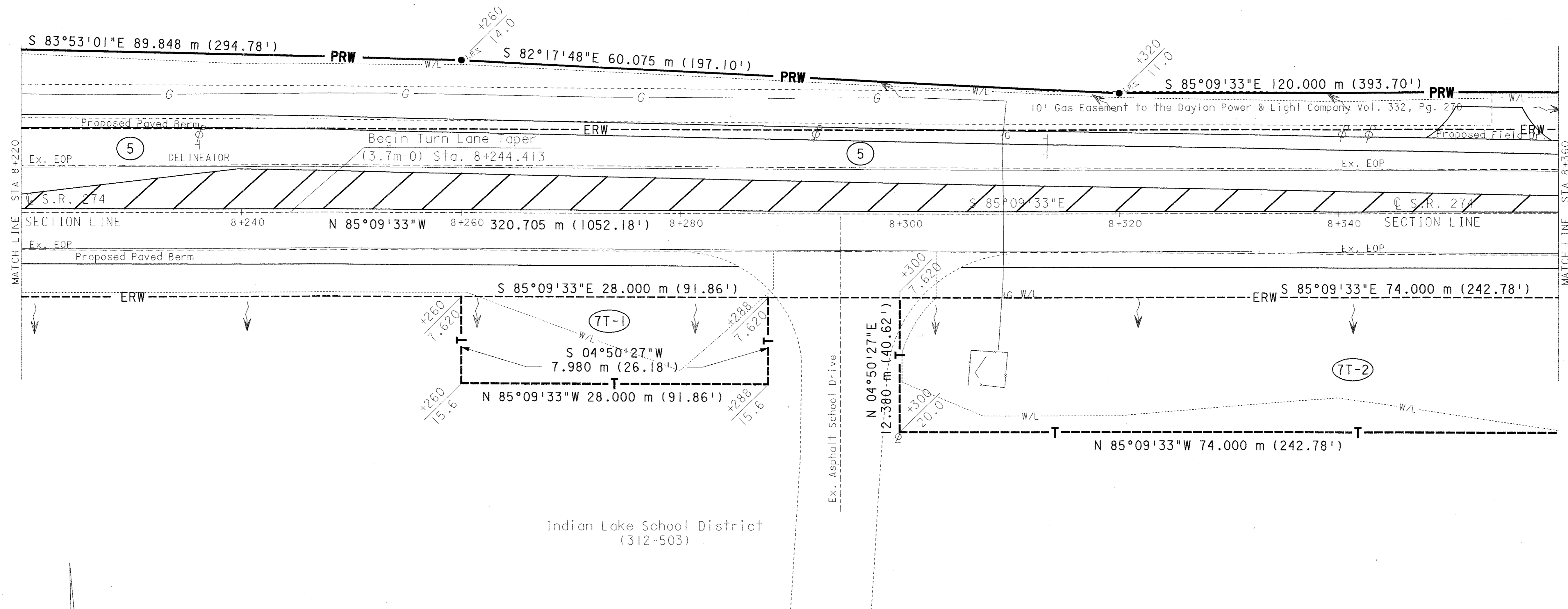

WASHINGTON TOWNSHIP SECTION 14 T7S R8E

Indian Lake School District (312-503)

SCALE (meters) 0 4 8 12 16 20

PID NO. 18782

DETAIL & RIGHT OF WAY PLAN S.R. 274 STA. 8+220 TO STA. 8+360

LOG-235/274-23.641/8.095

PLAN COMPLETED: August 3, 1998

REV	DATE	DESCRIPTION
Amy	9/8/98	Add 7T-1 and 7T-2

12 / 14

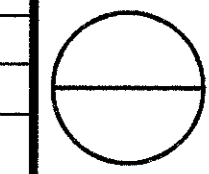

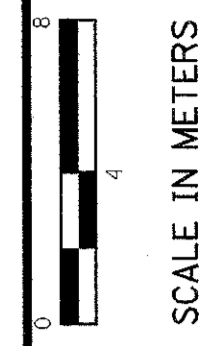
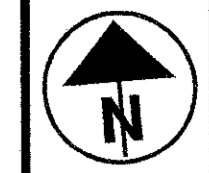

PID NO.  
**18782**

**DETAIL & RIGHT OF WAY PLAN**  
**S.R. 274 STA. 8+360 TO STA. 8+500**

**LOG-235 / 274-23.641 / 8.095**

**TANGENT TABLE**

- (1) S 04°50'27"W 7.620 m (25.00')
- (2) S 05°09'27"W 1.524 m (5.00')
- (3) N 57°19'11"W 3.263 m (10.71')
- (4) S 85°09'33"E 2.894 m (9.49')
- (5) S 04°50'27"W 1.524 m (5.00')

WASHINGTON TOWNSHIP SECTION 11 T7S R8E

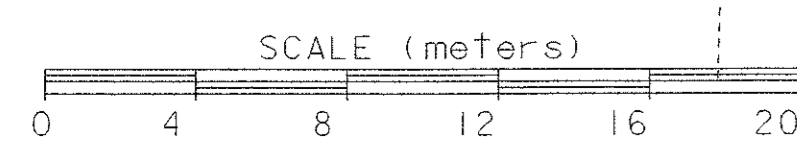
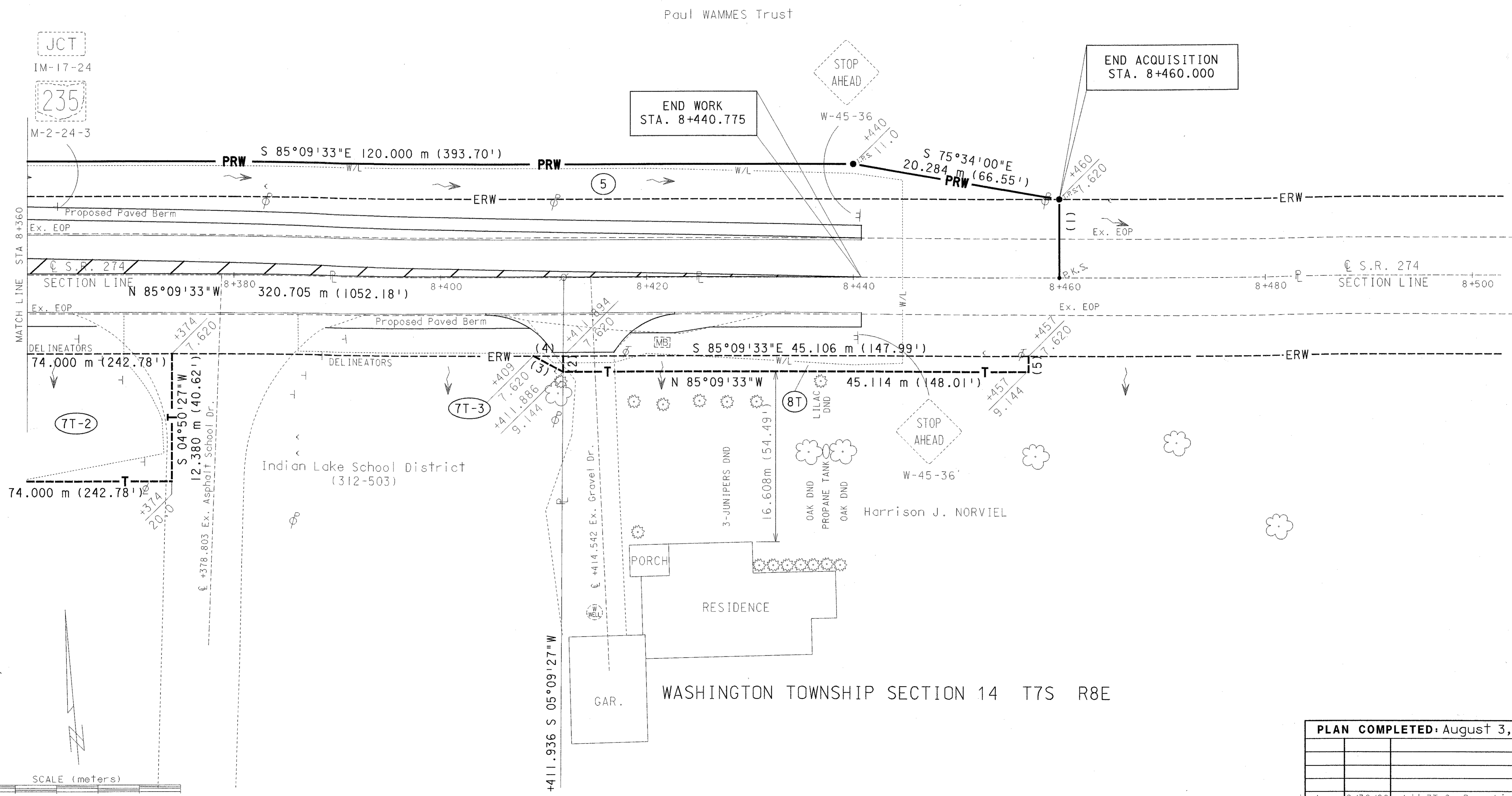

PLAN COMPLETED: August 3, 1998		
REV	DATE	DESCRIPTION
Amy	9/30/98	Add 7T-2; Rev. Limits



metric units

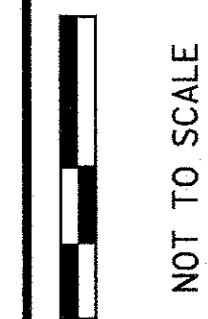
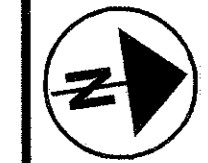

NOT TO SCALE

PID NO.

18782

S.R. 274

DETAIL OF SIGNING

INTERSECTION OF S.R. 235 AND S.R. 274

LOG-235 / 274-23.641 / 8.095

PLAN COMPLETED: August 3, 1998

REV	DATE	DESCRIPTION
Amy	9/30/98	Del. 4T, Rev. 5 & 5T

14 / 14

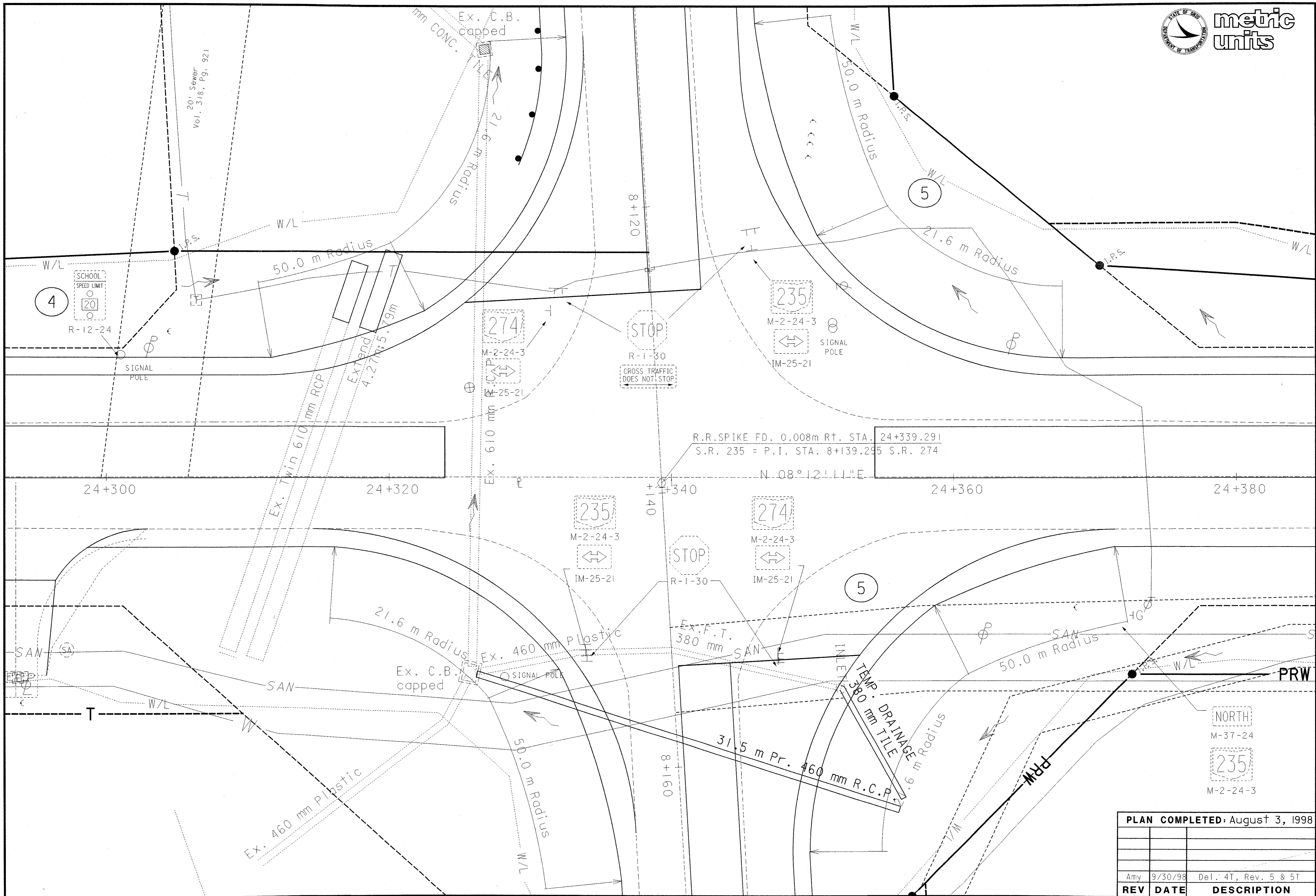
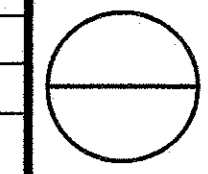

20" Sewer  
Vol. 318, Pg. 921

R.R. SPIKE FD. 0.008m Rt. STA. 24+339.291  
S.R. 235 = P.I. STA. 8+139.295 S.R. 274

NORTH  
M-37-24  
235  
M-2-24-3