

Received 11-22-94 OK 904



# Lee Surveying and Mapping Co.



Farm Surveys • Lot Surveys • Topography • Subdivisions • Construction Layout

143 EAST COLUMBUS AVENUE  
BELLEFONTAINE, OHIO 43311

(513) 593-7335

JEFFREY I. LEE, P.S.

## ZIESSLER 10.002 ACRES

LYING IN SECTION 27, LAKE TOWNSHIP AND SECTION 26, LIBERTY TOWNSHIP, TOWN 4, RANGE 14, CITY OF BELLEFONTAINE, LAKE TOWNSHIP, LOGAN COUNTY, OHIO.

BEING PART OF CITY LOT 4886 AS DEDICATED IN PLAT CABINET A, SLIDE 575, PART OF THE JOHN J. ZIESSLER ORIGINAL 103.13 ACRE TRACT AS DEEDED AND DESCRIBED IN DEED VOLUME 386, PAGE 705, AND PART OF THE JOHN J. ZIESSLER ORIGINAL 48.31 ACRE TRACT AS DEEDED AND DESCRIBED IN OFFICIAL RECORD 57, PAGE 985, ALL OF THE LOGAN COUNTY RECORDS OF PLATS AND DEEDS.

BEGINNING AT A 5/8 INCH IRON ROD FOUND AT THE NORTHWEST CORNER OF CITY LOT 4886.

**THENCE**, WITH THE NORTH LINE OF LOT 4886 AND THE SOUTH LINE OF KRISTINA DRIVE (60 FEET WIDE), S 86°-24'-10" E, A DISTANCE OF 70.00 FEET TO A 5/8 INCH IRON ROD SET AT THE TRUE POINT OF BEGINNING.

**THENCE**, WITH THE NORTH LINE OF LOT 4886 AND THE SOUTH LINE OF KRISTINA DRIVE, S 86°-24'-10" E, A DISTANCE OF 149.82 FEET TO A 5/8 INCH IRON ROD SET, PASSING THE SOUTHEAST CORNER OF KRISTINA DRIVE AT 114.07 FEET AND THE NORTHEAST CORNER OF LOT 4886 AT 148.31 FEET.

**THENCE**, WITH A CURVE TO THE LEFT HAVING A CENTRAL ANGLE OF 45°-11'-48", AN ARC LENGTH OF 244.54 FEET, A RADIUS OF 310.00 FEET, WITH A CHORD BEARING N 70°-59'-56" E, A CHORD DISTANCE OF 238.25 FEET TO A 5/8 INCH IRON ROD SET.

**THENCE**, THROUGH THE AFORESAID JOHN J. ZIESSLER ORIGINAL 103.13 ACRE TRACT, S 86°-01'-33" E, A DISTANCE OF 231.82 FEET TO A 5/8 INCH IRON ROD SET.

**THENCE**, WITH THE WEST LINE OF THE LOLA MAE PARK 55.97 ACRE TRACT (VOL. 306, PG. 575), S 3°-10'-16" W, A DISTANCE OF 508.00 FEET TO A 5/8 INCH IRON ROD SET.

**THENCE**, THROUGH THE SAID 103.13 ACRE TRACT, N 86°-01'-33" W, A DISTANCE OF 100.00 FEET TO A 5/8 INCH IRON ROD SET.

**THENCE**, THROUGH THE SAID 103.13 ACRE TRACT AND PASSING INTO THE JOHN J. ZIESSLER ORIGINAL 48.31 ACRE TRACT, S 30°-37'-13" W, A DISTANCE OF 431.88 FEET TO A 5/8 INCH IRON ROD SET.

**THENCE**, N 86°-01'-33" W, A DISTANCE OF 309.15 FEET TO A 5/8 INCH IRON ROD SET.

**THENCE**, N 3°35'-50" E, A DISTANCE OF 800.00 FEET TO THE POINT OF BEGINNING, PASSING THE SOUTH LINE OF LOT 4886 AT 530.00 FEET.

CONTAINING 10.002 ACRE OF WHICH 1.185 ACRE IS IN LOT 4886, 7.304 ACRE IS OUT OF THE ZIESSLER ORIGINAL 103.13 ACRE TRACT (SECTION 27, LAKE TOWNSHIP), AND 1.513 ACRE IS OUT OF THE ZIESSLER ORIGINAL 48.31 ACRE TRACT (SECTION 26 LIBERTY TOWNSHIP).

THE BASIS FOR BEARINGS IS BASED UPON THE CENTER-LINE OF KRISTINA DRIVE BEING S 86°-24'-10" E, AND ALL OTHER BEARINGS ARE FROM ANGLES AND DISTANCES MEASURED IN A FIELD SURVEY BY LEE SURVEYING AND MAPPING COMPANY ON SEPTEMBER 20, 1994.

DESCRIPTION PREPARED BY:

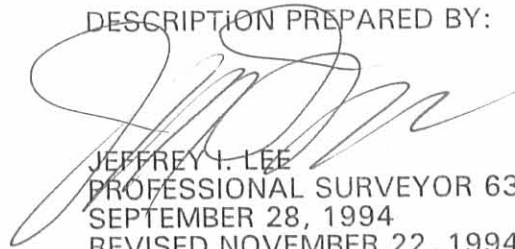
  
JEFFREY I. LEE  
PROFESSIONAL SURVEYOR 6359  
SEPTEMBER 28, 1994  
REVISED NOVEMBER 22, 1994

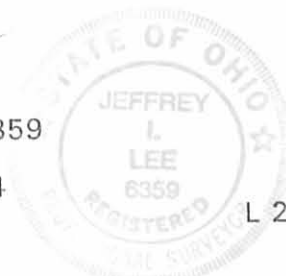

L 2226

ORIGINAL STAMP IN GREEN

4199 7D

Received 11-7-94 OK 904



# Lee Surveying and Mapping Co.



Farm Surveys • Lot Surveys • Topography • Subdivisions • Construction Layout

143 EAST COLUMBUS AVENUE  
BELLEFONTAINE, OHIO 43311

(513) 593-7335

JEFFREY I. LEE, P.S.

## JOHN J. ZIESSLER 60 FEET WIDE STREET EXTENSION EASEMENT

Lying in Section 27, Town 4, Range 14, City of Bellefontaine, Lake Township, Logan County, Ohio.

Being a 60 feet wide street extension easement across the John J. Ziessler original 103.13 acre tract as deeded and described in Volume 386, Page 705 of the Logan County Records of Deeds and the center-line being more particularly described as follows:

Beginning on the present center-line at the east terminus of Kristina Drive as dedicated on the Jadoville II plat filed in Plat Cabinet A, Slide 757 of the Logan County Records of Subdivisions.

THENCE, with the present center-line of Kristina Drive extended, S 86°-24'-10" E, a distance of 35.89 feet to a point.

THENCE, with a curve to the left having a central angle of 4°-31'-01", a radius of 280.00 feet, an arc length of 22.06 feet, on a chord bearing S 88°-39'-37" E, a distance of 22.06 feet to a the terminus of this easement.

This description is for easement purposes only and is not a boundary survey as defined in 4733-37 of the Ohio Administrative Code.

Description prepared by:

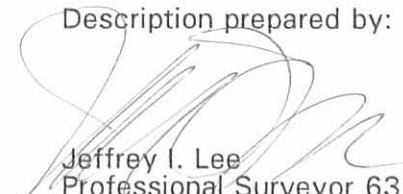
  
Jeffrey I. Lee  
Professional Surveyor 6359  
November 5, 1994



L 2226

INDEXED ON MAP  
499 10-1

Received 11-7-94 oic gch



# Lee Surveying and Mapping Co.



Farm Surveys • Lot Surveys • Topography • Subdivisions • Construction Layout

143 EAST COLUMBUS AVENUE  
BELLEFONTAINE, OHIO 43311

(513) 593-7335

JEFFREY I. LEE, P.S.

## JOHN J. ZIESSLER 10 FEET WIDE STORM SEWER EASEMENT

Lying in Section 27, Town 4, Range 14, City of Bellefontaine, Lake Township, Logan County, Ohio.

Being a 10 feet wide storm sewer easement across the John J. Ziessler original 103.13 acre tract as deeded and described in Volume 386, Page 705 of the Logan County Records of Deeds and being more particularly described as follows:

Beginning for reference at a 5/8 inch iron rod found at the northwest corner of Bellefontaine Lot 4886.

THENCE, with the north line of Lot 4886 and the south line of Kristina Drive (60 feet wide), S 86°-24'-10" E, a distance of 219.82 feet to a 5/8 inch iron rod set at the proposed point of curvature of future Kristina Drive.

THENCE, with a curve to the left having a central angle of 45°-11'-48", a radius of 310.00 feet, an arc length of 244.54 feet, on a chord bearing N 70°-59'-56" E, a distance of 238.25 feet to a 5/8 inch iron rod set.

THENCE, through the said 103.13 acre tract, S 86°-01'-33" E, a distance of 206.82 feet to the TRUE POINT OF BEGINNING.

THENCE, with the center-line of the 10 feet wide storm sewer easement the following two courses:

S 3°-07'-25" W, following the center-line of an existing 12 inch diameter pipe, a distance of 254.3 feet to a point.

S 1°-15'-45" W, with the center-line of a proposed new storm sewer pipe, a distance of 254 feet to the terminus of this easement. The said terminus point is on the south line of a proposed 10.002 acre tract and 16.5 feet west of the east property line of the said 103.13 acre tract.

This description is for easement purposes only and is not a boundary survey as defined in 4733-37 of the Ohio Administrative Code.

Description prepared by:

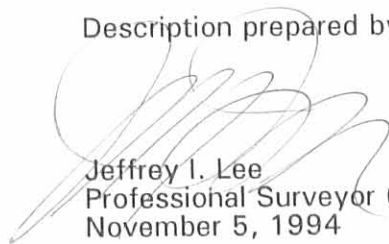
  
Jeffrey I. Lee  
Professional Surveyor 6359  
November 5, 1994



L 2226

ORIGINAL STAMP IN GREEN

INDEXED ON MAP  
4199 702

Received 11-7-94 OK 904



# Lee Surveying and Mapping Co.



Farm Surveys • Lot Surveys • Topography • Subdivisions • Construction Layout

143 EAST COLUMBUS AVENUE  
BELLEFONTAINE, OHIO 43311

(513) 593-7335

JEFFREY I. LEE, P.S.

## JOHN J. ZIESSLER RECREATIONAL USE EASEMENT

Lying in Section 27, Town 4, Range 14, City of Bellefontaine, Lake Township, Logan County, Ohio.

Being an easement for the construction, maintenance and use of a recreational area on the John J. Ziessler original 103.13 acre tract as deeded and described in Volume 386, Page 705 of the Logan County Records of Deeds and being more particularly described as follows:

Beginning at a point at the southeast corner of the said 103.13 acre tract. The said point is on the west line of the Lola Mae Park 55.97 acre tract, (Vol. 306, Pg. 575) and on the south line of Section 27.

THENCE, with the south line of Section 27 and the south line of the said 103.13 acre tract, N 86°-10'-10" W, a distance of 203.4 feet to a point.

THENCE, with the lines of a proposed 10.002 acre tract the following two courses:

N 30°-37'-13" E, a distance of 224.3 feet to a 5/8 inch iron rod set.

S 86°-01'-33" E, a distance of 100.00 feet to a 5/8 inch iron rod set.

THENCE, with the west line of the said 55.97 acre tract, S 3°-10'-16" W, a distance of 200.00 feet to the point of beginning.

Containing 0.7 acre plus or minus.

This description is for easement purposes only and is not a boundary survey as defined in 4733-37 of the Ohio Administrative Code.

Description prepared by:

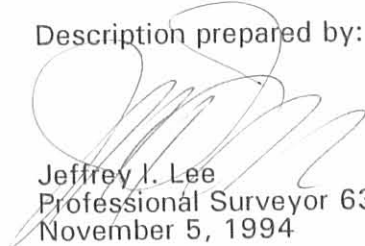
  
Jeffrey I. Lee  
Professional Surveyor 6359  
November 5, 1994



L 2226

ORIGINAL STAMP IN GREEN

INDEXED ON MAP  
4199 7D-3

Received 11-8 94 ok gcl



# Lee Surveying and Mapping Co.



Farm Surveys • Lot Surveys • Topography • Subdivisions • Construction Layout

143 EAST COLUMBUS AVENUE  
BELLEFONTAINE, OHIO 43311

(513) 593-7335

JEFFREY I. LEE, P.S.

## JOHN J. ZIESSLER 20 FEET SQUARE STORM SEWER EASEMENT

Lying in Section 26, Town 4, Range 14, City of Bellefontaine, Liberty Township, Logan County, Ohio.

Being an 20 feet square storm sewer easement on the John J. Ziessler original 48.31 acre tract as deeded and described in Official Record 57, Page 985 of the Logan County Records of Deeds and being more particularly described as follows:

Beginning for reference at a point at the northeast corner of the said 48.31 acre tract. The said point is on the west line of the Lola Mae Park 55.97 acre tract, (Vol. 306, Pg. 575) and on the north line of Section 26.

THENCE, with the north line of Section 26 and the north line of the said 48.31 acre tract, N 86°-10'-10" W, a distance of 203.4 feet to a point.

THENCE, with an east line of a proposed 10.002 acre tract, S 30°-37'-13" W, a distance of 36.08 feet to the TRUE POINT OF BEGINNING.

THENCE, S 59°-33'-47" E, a distance of 20 feet to a point.

THENCE, S 30°-37'-13" W, a distance of 20 feet to a point.

THENCE, N 59°-33'-47" W, a distance of 20 feet to a point.

THENCE, N 30°-37'-13" E, a distance of 20 feet to the point of beginning.

Containing 400 square feet.

This description is for easement purposes only and is not a boundary survey as defined in 4733-37 of the Ohio Administrative Code.

Description prepared by:

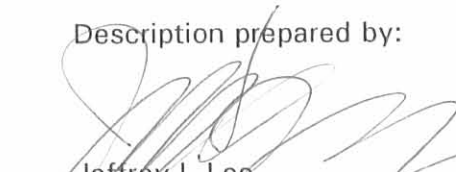
  
Jeffrey I. Lee  
Professional Surveyor 6359  
November 5, 1994  
Rev. November 8, 1994



L 2226

ORIGINAL SURVEY IN GREEN

INDEXED ON MAP  
4199 10-4

Received 11-9-74 JCL, OK



# Lee Surveying and Mapping Co.



Farm Surveys • Lot Surveys • Topography • Subdivisions • Construction Layout

143 EAST COLUMBUS AVENUE  
BELLEFONTAINE, OHIO 43311

(513) 593-7335

JEFFREY I. LEE, P.S.

## JOHN J. ZIESSLER SANITARY SEWER EASEMENT

Lying in Sections 26 and 27, Town 4, Range 14, City of Bellefontaine, Lake and Liberty Townships, Logan County, Ohio.

Being a 10 feet wide sanitary sewer easement on the John J. Ziessler original 48.31 acre tract as deeded and described in Official Record 57, Page 985, and the John J. Ziessler original 103.13 acre tract as deeded and described in Volume 386, Page 705 of the Logan County Records of Deeds and being more particularly described as follows:

Beginning for reference at a point at the southwest corner of Bellefontaine Lot 4886 (in Section 27, Town 4, Range 14).

THENCE, with the south line of Lot 4886, S 86°-24'-10" E, a distance of 65.0 feet to a point at the TRUE POINT OF BEGINNING.

THENCE, with the center-line of this described easement, parallel with the west line of said Lot 4886 and parallel and 5 feet distant from the west line of a proposed 10.002 acre tract, S 3°-35'-50" W, passing into Section 26, a distance of 530.0 feet to the terminus of this easement.

This description is for easement purposes only and is not a boundary survey as defined in 4733-37 of the Ohio Administrative Code.

Description prepared by:

  
Jeffrey I. Lee,  
Professional Surveyor 6359  
November 5, 1994  
Rev. November 8, 1994



L 2226

ORIGINAL STORED IN GREY

INDEXED ON MAP  
4199 705

Received 11-7-94 OK JCL



# Lee Surveying and Mapping Co.



Farm Surveys • Lot Surveys • Topography • Subdivisions • Construction Layout

143 EAST COLUMBUS AVENUE  
BELLEFONTAINE, OHIO 43311

(513) 593-7335

JEFFREY I. LEE, P.S.

## JOHN J. ZIESSLER 20 FEET WIDE STORM SEWER EASEMENT

Lying in Section 27, Town 4, Range 14, City of Bellefontaine, Lake Township, Logan County, Ohio.

Being a 20 feet wide storm sewer easement across the John J. Ziessler original 103.13 acre tract as deeded and described in Volume 386, Page 705 of the Logan County Records of Deeds and being more particularly described as follows:

Beginning for reference at a 5/8 inch iron rod found at the northwest corner of Bellefontaine Lot 4886.

THENCE, with the north line of Lot 4886 and the south line of Kristina Drive (60 feet wide), S 86°-24'-10" E, a distance of 219.82 feet to a 5/8 inch iron rod set at the proposed point of curvature of future Kristina Drive.

THENCE, with a curve to the left having a central angle of 45°-11'-48", a radius of 310.00 feet, an arc length of 244.54 feet, on a chord bearing N 70°-59'-56" E, a distance of 238.25 feet to a 5/8 inch iron rod set.

THENCE, through the said 103.13 acre tract, S 86°-01'-33" E, a distance of 206.82 feet to a point on the center-line of an existing 12 inch storm sewer pipe.

THENCE, with the center-line of a 10 feet wide storm sewer easement the following two courses:

S 3°-07'-25" W, following the center-line of the said existing 12 inch diameter pipe, a distance of 254.3 feet to a point.

S 1°-15'-45" W, with the center-line of a proposed new storm sewer pipe, a distance of 254 feet to the TRUE POINT OF BEGINNING. The said true point of beginning is on the south line of a proposed 10.002 acre tract and 16.5 feet west of the east property line of the said 103.13 acre tract.

THENCE, with the center-line of this 20 feet wide easement, S 1°-15'-45" W, a distance of 52.0 feet to the terminus of this easement.

This description is for easement purposes only and is not a boundary survey as defined in 4733-37 of the Ohio Administrative Code.

Description prepared by:

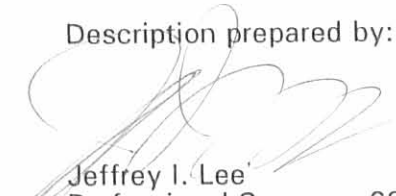
  
Jeffrey I. Lee  
Professional Surveyor 6359  
November 5, 1994



L 2226

ORIGINAL SET IN GREEN

INDEXED ON MAP  
4199 10-6

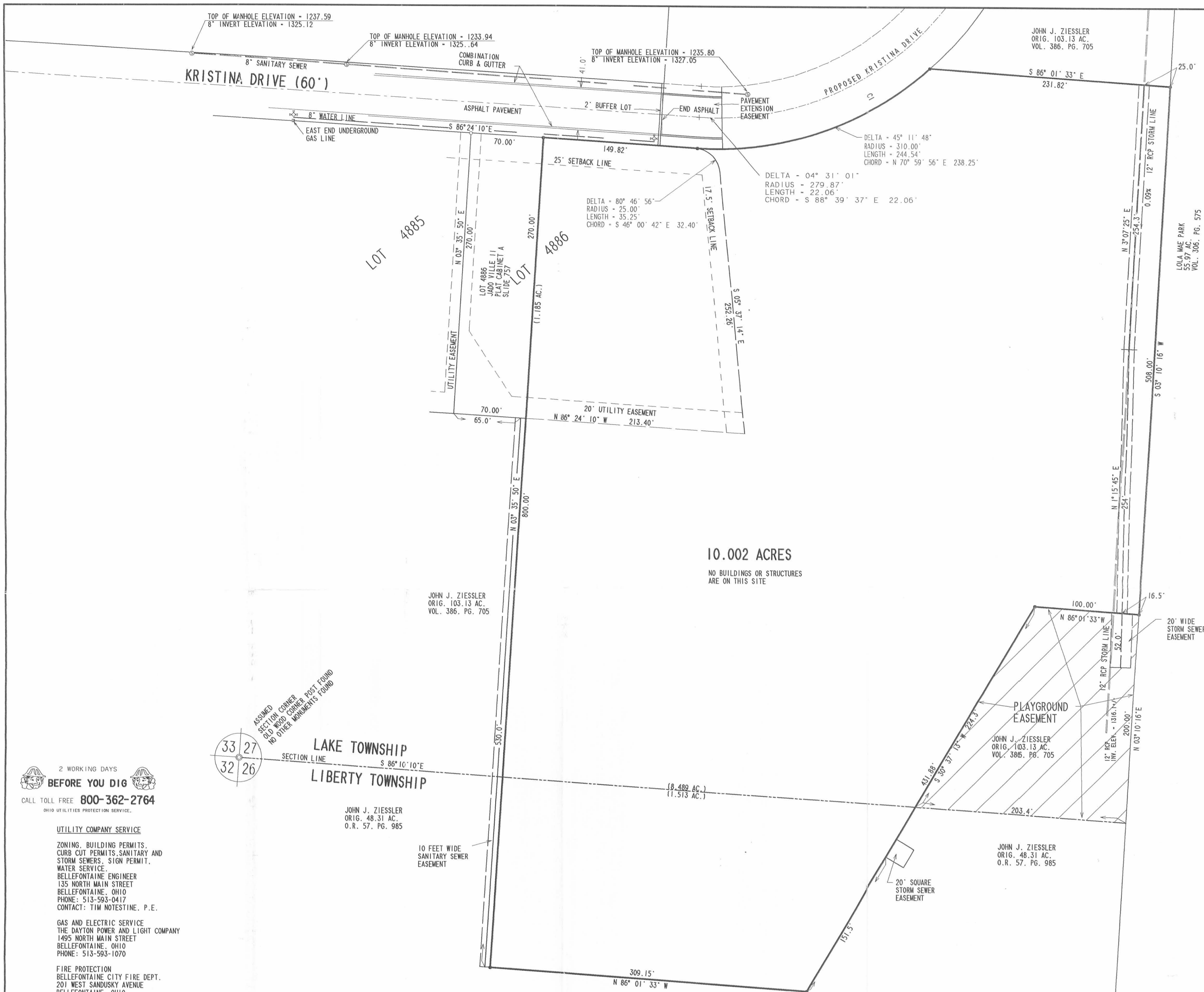

**LEGEND**

- ⊕ FIRE HYDRANT
- ⊕ GAS LINE WARNING POST
- ⊕ SANITARY MANHOLE
- ⊕ STORM MANHOLE
- 5/8" I. ROD FOUND
- 5/8" I. ROD SET

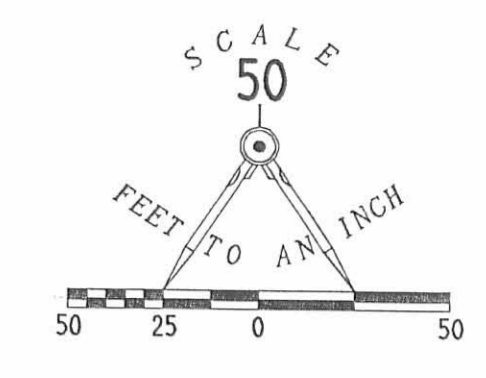

**DESCRIPTION**

LYING IN SECTION 27, LAKE TOWNSHIP AND SECTION 26, LIBERTY TOWNSHIP, TOWN 4, RANGE 14, CITY OF BELLEFONTAINE, LOGAN COUNTY, OHIO.

BEING PART OF CITY LOT 4886 AS DEDICATED IN PLAT CABINET A, SLIDE 575, PART OF THE JOHN J. ZIESSLER ORIGINAL 103.13 ACRE TRACT AS DEEDED AND DESCRIBED IN DEED VOLUME 386, PAGE 705, AND PART OF THE JOHN J. ZIESSLER ORIGINAL 48.31 ACRE TRACT AS DEEDED AND DESCRIBED IN OFFICIAL RECORD 57, PAGE 985, ALL OF THE LOGAN COUNTY RECORDS OF PLATS AND DEEDS.

BEGINNING AT A 5/8" IRON ROD FOUND AT THE NORTHWEST CORNER OF CITY LOT 4886.

THENCE, WITH THE NORTH LINE OF LOT 4886 AND THE SOUTH LINE OF KRISTINA DRIVE (60 FEET WIDE), S 86°-24'-10" E, A DISTANCE OF 70.00 FEET TO A 5/8" IRON ROD SET AT THE TRUE POINT OF BEGINNING.

THENCE, WITH THE NORTH LINE OF LOT 4886 AND THE SOUTH LINE OF KRISTINA DRIVE, S 86°-24'-10" E, A DISTANCE OF 149.82 FEET TO A 5/8" IRON ROD SET, PASSING THE SOUTHEAST CORNER OF KRISTINA DRIVE AT 114.07 FEET AND THE NORTHEAST CORNER OF LOT 4886 AT 148.31 FEET.

THENCE, WITH A CURVE TO THE LEFT HAVING A CENTRAL ANGLE OF 45°-11'-48", AN ARC LENGTH OF 244.54 FEET, A RADIUS OF 310.00 FEET, WITH A CHORD BEARING N 70°-59'-56" E, A CHORD DISTANCE OF 238.25 FEET TO A 5/8" IRON ROD SET.

THENCE, THROUGH THE AFORESAID JOHN J. ZIESSLER ORIGINAL 103.13 ACRE TRACT, S 86°-01'-33" E, A DISTANCE OF 231.82 FEET TO A 5/8" IRON ROD SET.

THENCE, WITH THE WEST LINE OF THE LOLA MAE PARK 55.97 ACRE TRACT (VOL. 306, PG. 575), S 3°-10'-16" W, A DISTANCE OF 508.00 FEET TO A 5/8" IRON ROD SET.

THENCE, THROUGH THE SAID 103.13 ACRE TRACT, N 86°-01'-33" W, A DISTANCE OF 100.00 FEET TO A 5/8" IRON ROD SET.

THENCE, THROUGH THE SAID 103.13 ACRE TRACT AND PASSING INTO THE JOHN J. ZIESSLER ORIGINAL 48.31 ACRE TRACT, S 30°-37'-13" W, A DISTANCE OF 431.88 FEET TO A 5/8" IRON ROD SET.

THENCE, N 86°-01'-33" W, A DISTANCE OF 309.15 FEET TO A 5/8" IRON ROD SET.

THENCE, N 3°-35'-50" E, A DISTANCE OF 800.00 FEET TO THE POINT OF BEGINNING, PASSING THE SOUTH LINE OF LOT 4886 AT 530.00 FEET.

CONTAINING 10.002 ACRE OF WHICH 1.185 ACRE IS IN LOT 4886, 7.304 ACRE IS OUT OF THE ZIESSLER ORIGINAL 103.13 ACRE TRACT (SECTION 27, LAKE TOWNSHIP), AND 1.513 ACRE IS OUT OF THE ZIESSLER ORIGINAL 48.31 ACRE TRACT (SECTION 26, LIBERTY TOWNSHIP).

THE BASIS FOR BEARINGS IS BASED UPON THE CENTER-LINE OF KRISTINA DRIVE BEING S 86°-24'-10" E, AND ALL OTHER BEARINGS ARE FROM ANGLES AND DISTANCES MEASURED IN A FIELD SURVEY BY LEE SURVEYING AND MAPPING COMPANY ON SEPTEMBER 20, 1994.

THIS DESCRIPTION WAS PREPARED BY JEFFREY I. LEE, PROFESSIONAL SURVEYOR 6359, ON SEPTEMBER 28, 1994, AND REVISED NOVEMBER 22, 1994.

**ALTA/ACSM SURVEY OF 10.002 ACRES  
SECTIONS 26 AND 27, TOWN 4, RANGE 14  
CITY OF BELLEFONTAINE  
LAKE TOWNSHIP, LOGAN COUNTY, OHIO**

TO NILO TWO LIMITED PARTNERSHIP; BANK ONE, CINCINNATI, N.A.; AND CHICAGO TITLE INSURANCE COMPANY: THIS IS TO STATE THAT THIS MAP OR PLAT AND THE SURVEY ON WHICH IT IS BASED WERE MADE IN ACCORDANCE WITH "MINIMUM STANDARD DETAIL REQUIREMENTS FOR ALTA/ACSM LAND TITLE SURVEYS," JOINTLY ESTABLISHED AND ADOPTED BY ALTA AND ACSM IN 1992, AND INCLUDES ITEMS 1, 3, 4, 6, 8, 10 AND 11 OF TABLE A THEREOF, AND PURSUANT TO THE ACCURACY STANDARDS (AS ADOPTED BY ALTA AND ACSM AND IN EFFECT ON THE DATE OF THIS STATEMENT) OF AN "URBAN" SURVEY.

THE PREMISES SHOWN HEREON ARE IN FLOOD ZONE "C", (AREA OF MINIMAL FLOODING), PER THE NATIONAL FLOOD INSURANCE RATE MAPS 390772 0115 C AND 390772 0120 C, DATED JANUARY 29, 1982.

THE UNDERGROUND UTILITIES SHOWN HAVE BEEN LOCATED FROM FIELD SURVEY INFORMATION AND EXISTING DRAWINGS. THE SURVEYOR MAKES NO GUARANTEE THAT THE UNDERGROUND UTILITIES SHOWN COMPRISE ALL SUCH UTILITIES IN THE AREA, EITHER IN SERVICE OR ABANDONED. THE SURVEYOR FURTHER DOES NOT WARRANT THAT THE UNDERGROUND UTILITIES SHOWN ARE IN THE EXACT LOCATION INDICATED, ALTHOUGH HE DOES STATE THAT THEY ARE LOCATED AS ACCURATELY AS POSSIBLE FROM INFORMATION AVAILABLE. THE SURVEYOR HAS NOT PHYSICALLY LOCATED THE UNDERGROUND UTILITIES.

CHICAGO TITLE INSURANCE COMPANY NUMBER 94060524 GER WITH AN EFFECTIVE DATE OF AUGUST 29, 1994, AND AMENDED BY TELEPHONE BY LEE SURVEYING BY MR. DAVID CONNER ON SEPTEMBER 28, 1994, IS THE BASIS FOR TITLE FOR THIS PROPERTY SURVEY. NONE OF THE EASEMENTS NOTED IN THIS TITLE COMMITMENT AFFECT THIS PROPERTY EXCEPT THE EASEMENTS AS SHOWN ON THE JADO VILLE II SUBDIVISION FOUND IN THE LOGAN COUNTY RECORDER'S PLAT CABINET A, SLIDE 757. THE SURVEYOR MAKES NO FURTHER WARRANTY AS TO THE EXISTENCE OR NON-EXISTENCE OF ADDITIONAL EASEMENTS THAT MAY AFFECT THIS PROPERTY.

2 WORKING DAYS  
**BEFORE YOU DIG**  
CALL TOLL FREE 800-362-2764  
OHIO UTILITIES PROTECTION SERVICE.

- UTILITY COMPANY SERVICE**
- ZONING, BUILDING PERMITS, CURB CUT PERMITS, SANITARY AND STORM SEWERS, SIGN PERMIT, WATER SERVICE, BELLEFONTAINE ENGINEER, 135 NORTH MAIN STREET, BELLEFONTAINE, OHIO, PHONE: 513-593-0417, CONTACT: TIM NOTESTINE, P.E.
- GAS AND ELECTRIC SERVICE**  
THE DAYTON POWER AND LIGHT COMPANY, 1495 NORTH MAIN STREET, BELLEFONTAINE, OHIO, PHONE: 513-593-1070
- FIRE PROTECTION**  
BELLEFONTAINE CITY FIRE DEPT., 201 WEST SANDUSKY AVENUE, BELLEFONTAINE, OHIO, PHONE: 513-599-6168
- TELEPHONE SERVICE**  
UNITED TELEPHONE COMPANY, 127 NORTH MAIN STREET, BELLEFONTAINE, OHIO, PHONE: 513-599-4131
- LCI (LITEL) INTERNATIONAL**  
112 EAST COURT STREET, BELLEFONTAINE, OHIO, PHONE: 513-592-3585
- CABLE TELEVISION SERVICE**  
SIMMONS CABLE TV, 113 NORTHVIEW DRIVE, BELLEFONTAINE, OHIO, PHONE: 513-599-6121

THE FOLLOWING POLICY HAS BEEN ESTABLISHED BY THE BELLEFONTAINE CITY PLANNING COMMISSION: "STORM WATER RETENTION SHALL BE BASED ON A 25 YEAR STORM WITH 2 HOUR TIME FRAME. THIS BASICALLY MEANS THE STORM WATER SHALL NOT RUN OFF AT A GREATER RATE AFTER DEVELOPMENT THAN IT WAS IN AN UNDEVELOPED STATE."

INDEXED ON MAP  
4199 78

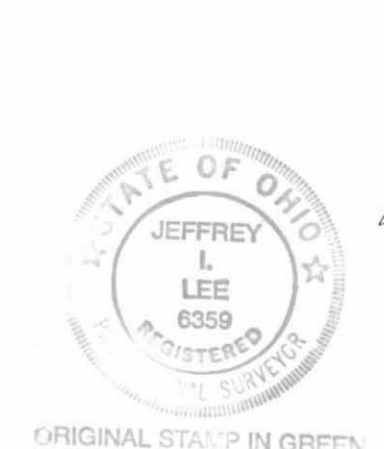

JEFFREY I. LEE  
PROFESSIONAL SURVEYOR 6359  
SEPTEMBER 28, 1994  
REVISED NOVEMBER 22, 1994  
NEW EASEMENTS ADDED NOVEMBER 4, 1994  
**LEE SURVEYING & MAPPING CO.**  
143 East Columbus Avenue  
BELLEFONTAINE, OHIO 43311  
(513) 593-7335



REC'D 2-29-96 SMY ac ✓



# Lee Surveying and Mapping Co., Inc.



Farm Surveys • Lot Surveys • Topography • Subdivisions • Construction Layout

143 EAST COLUMBUS AVENUE  
BELLEFONTAINE, OHIO 43311

(513) 593-7335  
FAX (513) 593-7444

## NILO TWO LIMITED PARTNERSHIP 20' SANITARY SEWER EASEMENT A

Lying in Section 26, Town 4, Range 14, City of Bellefontaine, Liberty Township, Logan County, Ohio.

Being a non-exclusive 20.00 feet wide sanitary sewer easement through the Nilo Two Limited Partnership 10.002 acre tract as deeded and described in Official Record 243, Page 663, Exhibit "A" of the Logan County Records of Deeds with the center-line being more particularly described as follows:

Beginning at a 5/8 inch iron rod set at the southwest corner of the said 10.002 acre tract.

THENCE, with the west line of the said 10.002 acre tract, N 3°-35'-50" E, a distance of 10.00 feet to the TRUE POINT OF BEGINNING.

THENCE, parallel with the south line of the 10.002 acre tract and 10.00 feet distant, S 86°-01'-33" E, a distance of 139.66 feet to a point at the terminus of this easement.

The basis for bearings is the south line of Kristina Drive being S 86°-24'-10" E, and all other bearings are from angles and distances measured in field surveys by Lee Surveying and Mapping Co., Inc. in 1994 and 1995.

Description prepared by:

Jeffrey I. Lee  
Professional Surveyor 6359  
February 28, 1996



L 2226

ORIGINAL STAMP IN GREEN

INDEXED ON MAP  
4199 001

REC'D 3-29-96 SML OK ✓



# Lee Surveying and Mapping Co., Inc.

Farm Surveys • Lot Surveys • Topography • Subdivisions • Construction Layout

143 EAST COLUMBUS AVENUE  
BELLEFONTAINE, OHIO 43311

(513) 593-7335  
FAX (513) 593-7444

## NILO TWO LIMITED PARTNERSHIP 10' SANITARY SEWER EASEMENT B

Lying in Sections 26 and 27, Town 4, Range 14, City of Bellefontaine, Liberty and Lake Townships, Logan County, Ohio.

Being a non-exclusive 10.00 feet wide sanitary sewer easement through the Nilo Two Limited Partnership 10.002 acre tract as deeded and described in Official Record 243, Page 663, Exhibit "A" of the Logan County Records of Deeds with the center-line being more particularly described as follows:

Beginning at a 5/8 inch iron rod set at the southwest corner of the said 10.002 acre tract.

THENCE, with the west line of the said 10.002 acre tract, N 3°-35'-50" E, a distance of 10.00 feet to a point.

THENCE, parallel with the south line of the 10.002 acre tract and 10.00 feet distant, S 86°-01'-33" E, a distance of 129.66 feet to the TRUE POINT OF BEGINNING.

THENCE, N 25°-58'-16" E, a distance of 380.00 feet to a point.

THENCE, N 7°-17'-23" E, a distance of 138.00 feet to a point.

THENCE, N 19°-26'-04" W, a distance of 148.65 feet to a point.

THENCE, N 70°-21'-15" E, a distance of 235.00 feet to a point at the terminus of this easement.

The basis for bearings is the south line of Kristina Drive being S 86°-24'-10" E, and all other bearings are from angles and distances measured in field surveys by Lee Surveying and Mapping Co., Inc. in 1994 and 1995.

Description prepared by:

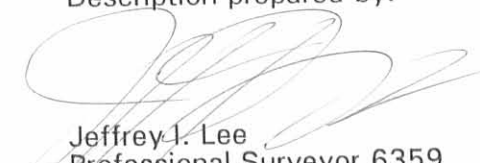
  
Jeffrey J. Lee  
Professional Surveyor 6359  
February 28, 1996



L 2226

ORIGINAL STAMP IN GREEN

INDEXED ON MAP  
4199 8D-2

REC'D 2-29-96 SWJ OK ✓



# Lee Surveying and Mapping Co., Inc.

Farm Surveys • Lot Surveys • Topography • Subdivisions • Construction Layout

143 EAST COLUMBUS AVENUE  
BELLEFONTAINE, OHIO 43311

(513) 593-7335  
FAX (513) 593-7444

## NILO TWO LIMITED PARTNERSHIP 10' SANITARY SEWER EASEMENT C

Lying in Section 27, Town 4, Range 14, City of Bellefontaine, Lake Township, Logan County, Ohio.

Being a non-exclusive 10.00 feet wide sanitary sewer easement through the Nilo Two Limited Partnership 10.002 acre tract as deeded and described in Official Record 243, Page 663, Exhibit "A" of the Logan County Records of Deeds with the center-line being more particularly described as follows:

Beginning at a 5/8 inch iron rod set at the southwest corner of the said 10.002 acre tract.

THENCE, with the west line of the said 10.002 acre tract, N 3°-35'-50" E, a distance of 10.00 feet to a point.

THENCE, parallel with the south line of the 10.002 acre tract and 10.00 feet distant, S 86°-01'-33" E, a distance of 129.66 feet to a point.

THENCE, N 25°-58'-16" E, a distance of 380.00 feet to the TRUE POINT OF BEGINNING.

THENCE, N 76°-21'-21" W, a distance of 185.00 feet to a point at the terminus of this easement.

The basis for bearings is the south line of Kristina Drive being S 86°-24'-10" E, and all other bearings are from angles and distances measured in field surveys by Lee Surveying and Mapping Co., Inc. in 1994 and 1995.

Description prepared by:

  
Jeffrey I. Lee  
Professional Surveyor 6359  
February 28, 1996



L 2226

ORIGINAL STAMP IN GREEN

INDEXED ON MAP  
4199 8D-3

REC'D 2-29-96 Smg OK ✓



# Lee Surveying and Mapping Co., Inc.



Farm Surveys • Lot Surveys • Topography • Subdivisions • Construction Layout

143 EAST COLUMBUS AVENUE  
BELLEFONTAINE, OHIO 43311

(513) 593-7335  
FAX (513) 593-7444

## NILO TWO LIMITED PARTNERSHIP 10' SANITARY SEWER EASEMENT D

Lying in Section 27, Town 4, Range 14, City of Bellefontaine, Lake Township, Logan County, Ohio.

Being a non-exclusive 10.00 feet wide sanitary sewer easement through the Nilo Two Limited Partnership 10.002 acre tract as deeded and described in Official Record 243, Page 663, Exhibit "A" of the Logan County Records of Deeds with the center-line being more particularly described as follows:

Beginning at a 5/8 inch iron rod set at the southwest corner of the said 10.002 acre tract.

THENCE, with the west line of the said 10.002 acre tract, N 3°-35'-50" E, a distance of 10.00 feet to a point.

THENCE, parallel with the south line of the 10.002 acre tract and 10.00 feet distant, S 86°-01'-33" E, a distance of 129.66 feet to a point.

THENCE, N 25°-58'-16" E, a distance of 380.00 feet to a point.

THENCE, N 7°-17'-23" E, a distance of 138.00 feet to the TRUE POINT OF BEGINNING.

THENCE, S 81°-00'-05" E, a distance of 150.00 feet to a point at the terminus of this easement.

The basis for bearings is the south line of Kristina Drive being S 86°-24'-10" E, and all other bearings are from angles and distances measured in field surveys by Lee Surveying and Mapping Co., Inc. in 1994 and 1995.

Description prepared by:

  
Jeffrey I. Lee  
Professional Surveyor 6359  
February 28, 1996



L 2226

ORIGINAL STAMP IN GREEN

INDEXED ON MAP  
4199 8D-4

1 REC'D 2-29-96 Survey OK ✓



# Lee Surveying and Mapping Co., Inc.



Farm Surveys • Lot Surveys • Topography • Subdivisions • Construction Layout

143 EAST COLUMBUS AVENUE  
BELLEFONTAINE, OHIO 43311

(513) 593-7335  
FAX (513) 593-7444

## NILO TWO LIMITED PARTNERSHIP 10' WATER LINE EASEMENT E

Lying in Sections 26 and 27, Town 4, Range 14, City of Bellefontaine, Liberty and Lake Townships, Logan County, Ohio.

Being a non-exclusive 10.00 feet wide water line easement through the Nilo Two Limited Partnership 10.002 acre tract as deeded and described in Official Record 243, Page 663, Exhibit "A" of the Logan County Records of Deeds with the center-line being more particularly described as follows:

Beginning at a 5/8 inch iron rod set at the northwest corner of the said 10.002 acre tract and on the south right-of way of Kristina Drive (60 feet wide).

THENCE, with the north line of the said 10.002 acre tract, S 86°-24'-10" E, a distance of 120.07 feet to the TRUE POINT OF BEGINNING.

THENCE, S 3°-35'-49" W, a distance of 36.24 feet to a point.

THENCE, with a curve to the left having a central angle of 29°-03'-41", a radius of 228.52 feet, an arc length of 115.91 feet on a chord bearing S 10°-56'-13" E, a chord distance of 114.67 feet to a point.

THENCE, S 25°-28'-04" E, a distance of 153.19 feet to a point.

THENCE, with a curve to the right having a central angle of 14°-45'-04", a radius of 195.00 feet, an arc length of 50.20 feet on a chord bearing S 18°-05'-40" E, a chord distance of 50.07 feet to a point.

THENCE, with a curve to the right having a central angle of 36°-41'-26", a radius of 195.00 feet, an arc length of 124.87 feet on a chord bearing S 7°-37'-27" W, a chord distance of 122.75 feet to a point.

THENCE, S 25°-58'-16" W, a distance of 168.60 feet to a point.

THENCE, S 70°-00'-42" W, a distance of 184.38 feet to a point on the west line of the 10.002 acre tract and the terminus of this easement.

The basis for bearings is the south line of Kristina Drive being S 86°-24'-10" E, and all other bearings are from angles and distances measured in field surveys by Lee Surveying and Mapping Co., Inc. in 1994 and 1995.

Description prepared by:

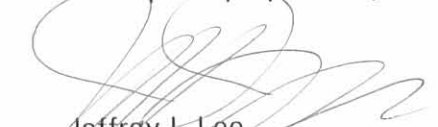
  
Jeffrey I. Lee  
Professional Surveyor 6359  
February 28, 1996



L 2226

ORIGINAL STAMP IN GREEN

INDEXED ON MAP  
4199 8D-5

REC'D 2-29-96 SMLY OK ✓



# Lee Surveying and Mapping Co., Inc.

Farm Surveys • Lot Surveys • Topography • Subdivisions • Construction Layout

143 EAST COLUMBUS AVENUE  
BELLEFONTAINE, OHIO 43311

(513) 593-7335  
FAX (513) 593-7444

## NILO TWO LIMITED PARTNERSHIP 10' WATER LINE EASEMENT F

Lying in Section 27, Town 4, Range 14, City of Bellefontaine, Lake Township, Logan County, Ohio.

Being a non-exclusive 10.00 feet wide water line easement through the Nilo Two Limited Partnership 10.002 acre tract as deeded and described in Official Record 243, Page 663, Exhibit "A" of the Logan County Records of Deeds with the center-line being more particularly described as follows:

Beginning at a 5/8 inch iron rod set at the northwest corner of the said 10.002 acre tract and on the south right-of way of Kristina Drive (60 feet wide).

THENCE, with the north line of the said 10.002 acre tract, S 86°-24'-10" E, a distance of 120.07 feet to a point.

THENCE, S 3°-35'-49" W, a distance of 36.24 feet to a point.

THENCE, with a curve to the left having a central angle of 29°-03'-41", a radius of 228.52 feet, an arc length of 115.91 feet on a chord bearing S 10°-56'-13" E, a chord distance of 114.67 feet to a point.

THENCE, S 25°-28'-04" E, a distance of 62.93 feet to the TRUE POINT OF BEGINNING.

THENCE, N 66°-28'-17" E, a distance of 63.00 feet to a point.

THENCE, N 70°-21'-15" E, a distance of 168.93 feet to a point at the terminus of this easement.

The basis for bearings is the south line of Kristina Drive being S 86°-24'-10" E, and all other bearings are from angles and distances measured in field surveys by Lee Surveying and Mapping Co., Inc. in 1994 and 1995.

Description prepared by:

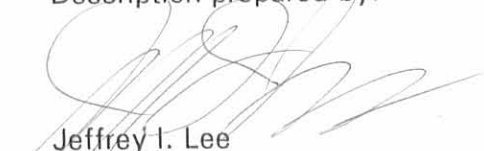
  
Jeffrey I. Lee  
Professional Surveyor 6359  
February 28, 1996



L 2226

ORIGINAL STAMP IN GREEN

INDEXED ON MAP  
4199 8D-LP

REC'D 2-29-96 8Mly OK ✓



# Lee Surveying and Mapping Co., Inc.



Farm Surveys • Lot Surveys • Topography • Subdivisions • Construction Layout

143 EAST COLUMBUS AVENUE  
BELLEFONTAINE, OHIO 43311

(513) 593-7335  
FAX (513) 593-7444

## NILO TWO LIMITED PARTNERSHIP 10' WATER LINE EASEMENT G

Lying in Section 27, Town 4, Range 14, City of Bellefontaine, Lake Township, Logan County, Ohio.

Being a non-exclusive 10.00 feet wide water line easement through the Nilo Two Limited Partnership 10.002 acre tract as deeded and described in Official Record 243, Page 663, Exhibit "A" of the Logan County Records of Deeds with the center-line being more particularly described as follows:

Beginning at a 5/8 inch iron rod set at the northwest corner of the said 10.002 acre tract and on the south right-of way of Kristina Drive (60 feet wide).

THENCE, with the north line of the said 10.002 acre tract, S 86°-24'-10" E, a distance of 120.07 feet to a point.

THENCE, S 3°-35'-49" W, a distance of 36.24 feet to a point.

THENCE, with a curve to the left having a central angle of 29°-03'-41", a radius of 228.52 feet, an arc length of 115.91 feet on a chord bearing S 10°-56'-13" E, a chord distance of 114.67 feet to a point.

THENCE, S 25°-28'-04" E, a distance of 153.19 feet to a point.

THENCE, with a curve to the right having a central angle of 14°-45'-04", a radius of 195.00 feet, an arc length of 50.20 feet on a chord bearing S 18°-05'-40" E, a chord distance of 50.07 feet to the TRUE POINT OF BEGINNING.

THENCE, N 84°-55'-38" E, a distance of 72.78 feet to a point.

THENCE, S 81°-00'-05" E, a distance of 75.00 feet to a point at the terminus of this easement.

The basis for bearings is the south line of Kristina Drive being S 86°-24'-10" E, and all other bearings are from angles and distances measured in field surveys by Lee Surveying and Mapping Co., Inc. in 1994 and 1995.

Description prepared by:

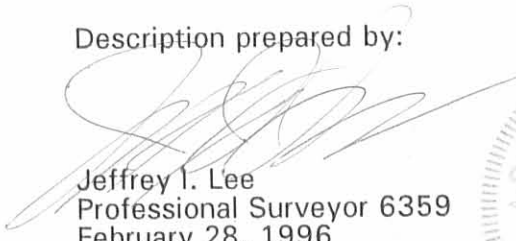
  
Jeffrey I. Lee  
Professional Surveyor 6359  
February 28, 1996



L 2226

ORIGINAL STAMP IN GREEN

INDEXED ON MAP  
4199 8D-7

REC'D 2-29-96 gmy or ✓



# Lee Surveying and Mapping Co., Inc.



Farm Surveys • Lot Surveys • Topography • Subdivisions • Construction Layout

143 EAST COLUMBUS AVENUE  
BELLEFONTAINE, OHIO 43311

(513) 593-7335  
FAX (513) 593-7444

## NILO TWO LIMITED PARTNERSHIP 10' STORM SEWER EASEMENT H

Lying in Sections 26 and 27, Town 4, Range 14, City of Bellefontaine, Liberty and Lake Township, Logan County, Ohio.

Being a non-exclusive 10.00 feet wide storm sewer easement through the Nilo Two Limited Partnership 10.002 acre tract as deeded and described in Official Record 243, Page 663, Exhibit "A" of the Logan County Records of Deeds with the center-line being more particularly described as follows:

Beginning at a 5/8 inch iron rod set at the southeast corner of the said 10.002 acre tract.

THENCE, with the easterly line of the said 10.002 acre tract, N 30°-37'-13" E, a distance of 165.40 feet to the TRUE POINT OF BEGINNING.

THENCE, N 50°-00'-00" W, a distance of 206.80 feet to a point.

THENCE, N 19°-33'-00" E, a distance of 170.46 feet to a point.

THENCE, N 36°-00'-35" W, a distance of 127.27 feet to a point at the terminus of this easement on the south line of Bellefontaine City Lot 4886 and the south line of an existing 20.00 feet wide utility easement.

The basis for bearings is the south line of Kristina Drive being S 86°-24'-10" E, and all other bearings are from angles and distances measured in field surveys by Lee Surveying and Mapping Co., Inc. in 1994 and 1995.

Description prepared by:

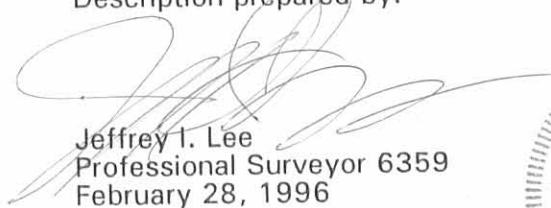
  
Jeffrey I. Lee  
Professional Surveyor 6359  
February 28, 1996



L 2226

ORIGINAL STAMP IN GREEN

INDEXED ON MAP  
4199 80-8



REC'D 2-29-96 Dwy OK ✓



# Lee Surveying and Mapping Co., Inc.



Farm Surveys • Lot Surveys • Topography • Subdivisions • Construction Layout

143 EAST COLUMBUS AVENUE  
BELLEFONTAINE, OHIO 43311

(513) 593-7335  
FAX (513) 593-7444

## NILO TWO LIMITED PARTNERSHIP 10' STORM SEWER EASEMENT J

Lying in Sections 27, Town 4, Range 14, City of Bellefontaine, Lake Township, Logan County, Ohio.

Being a non-exclusive 10.00 feet wide storm sewer easement through the Nilo Two Limited Partnership 10.002 acre tract as deeded and described in Official Record 243, Page 663, Exhibit "A" of the Logan County Records of Deeds with the center-line being more particularly described as follows:

Beginning at a 5/8 inch iron rod set at the northeast corner of the said 10.002 acre tract.

THENCE, with the north line of the said 10.002 acre tract, N 86°-01'-33" W, a distance of 25.00 feet to the TRUE POINT OF BEGINNING.

THENCE, S 3°-10'-16" W, a distance of 508.00 feet to a point on a south line of the said 10.002 acre tract and the terminus of this easement.

The basis for bearings is the south line of Kristina Drive being S 86°-24'-10" E, and all other bearings are from angles and distances measured in field surveys by Lee Surveying and Mapping Co., Inc. in 1994 and 1995.

Description prepared by:

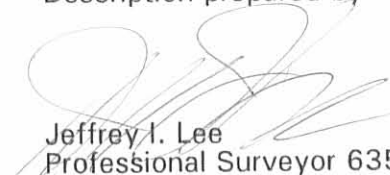
  
Jeffrey I. Lee  
Professional Surveyor 6359  
February 28, 1996



L 2226

ORIGINAL STAMP IN GREEN

INDEXED ON MAP  
4199 8D9

- LEGEND
- 5/8" I. ROD SET
  - 5/8" I. ROD FOUND

CURVE	DELTA ANGLE	RADIUS	ARC	TANGENT	CHORD	CHORD BEARING
C 1	29°03'41"	228.52'	115.91'	59.23'	114.67'	S 10°56'13"E
C 2	14°45'04"	195.00'	50.20'	25.24'	50.07'	S 18°05'40"E
C 3	35°41'26"	193.00'	124.87'	64.66'	122.75'	S 07°37'27"W
C 4	45°11'48"	310.00'	244.54'	129.03'	238.25'	H 70°59'56"E

60' WIDE STREET EXT. EASEMENT  
O.R. 243, PG. 663, EXHIBIT "D"

JOHN J. ZIESSLER  
O.R. 103, P. 13 ACRES  
VOL. 388, PG. 705

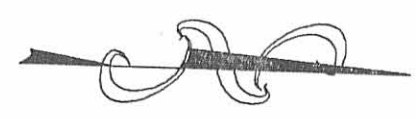
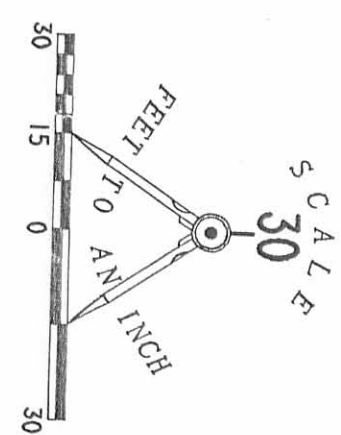

KRISTINA DRIVE (60')

LOT 4886  
JADO VILLE II  
PLAT CABINET A  
SLIDE 757

LOT 4886

LOT 4886

NILO TWO LIMITED PARTNERSHIP  
(AN OHIO LIMITED PARTNERSHIP)  
10.002 ACRES  
O.R. 243, PG. 663, EXHIBIT "A"

JOHN J. ZIESSLER  
O.R. 103, P. 13 ACRES  
VOL. 388, PG. 705

REGISTRAR'S USE EASEMENT  
O.R. 243, PG. 670

JOHN J. ZIESSLER  
O.R. 48, P. 31 ACRES  
O.R. 57, PG. 985

SEC. 27, T-4, R-14  
SEC. 26, T-4, R-14

MAP OF UTILITY EASEMENTS  
THROUGH THE NILO TWO LIMITED PARTNERSHIP 10.002 ACRE TRACT  
OFFICIAL RECORD 243, PG. 663, EXHIBIT "A"  
SECTIONS 26 AND 27, TOWN 4, RANGE 14  
CITY OF BELLEFONTAINE  
LAKE AND LIBERTY TOWNSHIPS  
LOGAN COUNTY, OHIO

2 WORKING DAYS  
BEFORE YOU DIG  
CALL TOLL FREE 800-362-2764  
OR VISIT US ONLINE AT WWW.STATEOFOHIO.GOV



PREPARED BY:  
JEFFREY L. LEE  
PROFESSIONAL SURVEYOR 6359  
NOVEMBER 10, 1995  
LEE SURVEYING & MAPPING CO., INC.  
CORPORATE OFFICE  
Bellefontaine, Ohio 43011  
(513) 592-7335

D 268 NILOESWT L-2286-1