

Sidesinger Survey - Monroe, Twp.

AC Fence line

AB " "

BC Survey line only.

ABC = 2.957 Acres
 & Right To
 Line BC = $\frac{1645}{3.60}$ Acres.

613
 INDEXED ON MAP

July - 24 - 1926

Clear

Wright
 Bob McCook

24

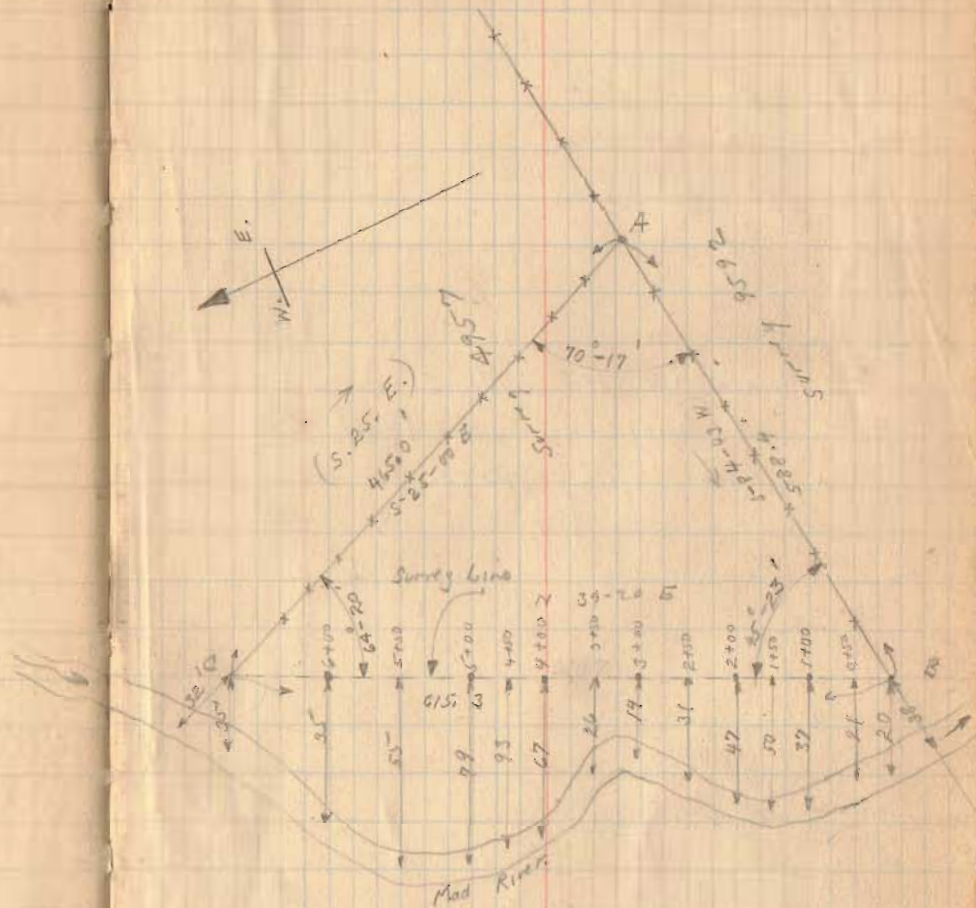

Measurements To & of creek

DEED 10-3-01 SWY OIL

Lee Surveying and Mapping Co., Inc.

Land Surveys • Topography • Subdivisions • Construction Layout

117 N. Madriver St.
Bellefontaine OH 43311

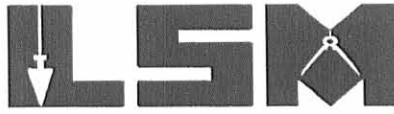

Phone: (937) 593-7335
Fax: (937) 593-7444

SIDESINGER 71.522 ACRES

Lying in Virginia Military Survey 4957, Jefferson and Monroe Townships, Logan County, Ohio.

Being all of the Melvin Sidesinger 3.14 acre tract and 0.693 acre tract as deeded and described in Volume 359, Page 580, Tract I and Tract II of the Logan County Record of Deeds and being part of the Melvin Sidesinger 106.98 acre tract as deeded and described in Official Record 341, Page 612, Tract I of the Logan County Records of Deeds and being more particularly described as follows:

Beginning at a railroad spike found at the intersection of the center-line of County Highway 5 and County Highway 29.

THENCE, with the center-line of County Highway 29 (60 feet wide), the following three (3) courses:

N 39°-55'-08" W, a distance of 1201.50 feet to a MAG nail set.

With a curve to the left having a central angle of 54°-51'-37", a radius of 320.00 feet, an arc length of 306.40 feet and having a chord bearing N 67°-20'-57" W, a distance of 294.83 feet to a MAG nail set.

S 85°-13'-15" W, a distance of 460.46 feet to a MAG nail set.

THENCE, with the east line of the Steven R. Fansler 21.66 acre tract (O.R. 139, Pg. 830, Parcel One), N 9°-41'-25" W, a distance of 679.71 feet to a 5/8 inch iron rod set, passing a 5/8 inch iron rod set at 30.12 feet.

THENCE, with the north line of Virginia Military Survey 4957 and the south line of the Steven R. Fansler 111.67 acre tract (O.R. 139, Pg. 830, Parcel Two), N 63°-18'-14" E, a distance of 1848.00 feet to a 5/8 inch iron rod set.

THENCE, with the west lines of the Pamela K. Hook, ET AL 73.634 acre tract (O.R. 437, Pg. 242) and the Jacqueline A. Sidders 1.640 acre tract (O.R. 205, Pg. 975), S 23°-36'-36" E, a distance of 1886.00 feet to a railroad spike found, passing a 5/8 inch iron rod set at 1854.41 feet.

THENCE, with the center-line of County Highway 5 (60 feet wide), S 48°-08'-40" W, a distance of 187.60 feet to a 5/8 inch iron rod found.

THENCE, continuing with the center-line of County Highway 5, S 45°-17'-42" W, a distance of 914.93 feet to the point of beginning.

Containing 71.522 acres, of which 19.111 acres are in Jefferson Township, 52.411 acres are in Monroe Township and 2.107 acres are within the highway rights-of-way.

The basis for bearings is the center-line of County Highway 5 at the point of beginning, being S 45°-17'-42" W, and all other bearings are from angles and distances measured in a field survey by Lee Surveying and Mapping Co., Inc. on September 17, 2001.

Description prepared by:

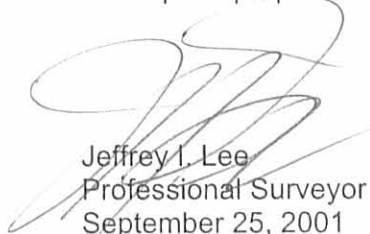

ORIGINAL STAMP IN GREEN

Jeffrey I. Lee
Professional Surveyor 6359
September 25, 2001

L-3221

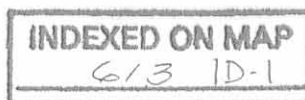

Lee Surveying and Mapping Co., Inc.

Land Surveys • Topography • Subdivisions • Construction Layout

117 N. Madriver St.
Bellefontaine OH 43311



Phone: (937) 593-7335
Fax: (937) 593-7444

SIDESINGER 22.222 ACRES

Lying in Virginia Military Survey 4957, Monroe Township, Logan County, Ohio.

Being out of the Melvin Sidesinger 106.98 acre tract as deeded and described in Official Record 341, Page 612, Tract I of the Logan County Records of Deeds and being more particularly described as follows:

Beginning at a railroad spike found at the intersection of the center-line of County Highway 5 and County Highway 29.

THENCE, with the center-line of County Highway 5 (60 feet wide), N 45°-17'-42" E, a distance of 699.93 feet to a MAG nail set.

THENCE, with the west line of the Herbert E. Foreman, Trustee 10.00 acre tract (O.R. 270, Pg. 109, Tract 2), S 23°-32'-28" E, a distance of 1181.40 feet to a 5/8 inch iron rod set, passing a 5/8 inch iron rod set at 32.17 feet.

THENCE, with the northwesterly line of the Herbert E. Foreman, Trustee 3.6 acre tract (O.R. 270, Pg. 109, Tract 5), S 43°-22'-31" W, a distance of 412.50 feet to a 5/8 inch iron rod found.

THENCE, with the south line of Virginia Military Survey 4957 and the north line of the Thomas W. Godwin 189.963 acre tract (O.R. 331, Pg. 195), N 84°-55'-29" W, a distance of 516.27 feet to a 5/8 inch iron rod set.

THENCE, with an easterly line of the said 189.963 acre tract, N 41°-20'-22" W, a distance of 627.56 feet to a MAG nail set, passing a 5/8 inch iron rod found at 595.65 feet.

THENCE, with the center-line of County Highway 5, N 28°-44'-51" E, a distance of 330.00 feet to a 1 inch square iron bar found.

THENCE, with the center-line of County Highway 5, N 45°-17'-42" E, a distance of 116.19 feet to the point of beginning.

Containing 22.222 acres, of which 0.788 acre is within the highway right-of-way.

The basis for bearings is the center-line of County Highway 5 at the point of beginning, being S 45°-17'-42" W, and all other bearings are from angles and distances measured in a field survey by Lee Surveying and Mapping Co., Inc. on September 17, 2001.

Description prepared by:



ORIGINAL STAMP IN GREEN

Jeffrey I. Lee
Jeffrey I. Lee
Professional Surveyor 6359
September 25, 2001

L-3221

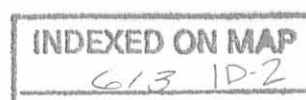

Lee Surveying and Mapping Co., Inc.

Land Surveys • Topography • Subdivisions • Construction Layout

117 N. Madriver St.
Bellefontaine OH 43311



Phone: (937) 593-7335
Fax: (937) 593-7444

SIDESINGER 24.045 ACRES

Lying in Virginia Military Survey 4957, Monroe Township, Logan County, Ohio.

Being out of the Melvin Sidesinger 106.98 acre tract as deeded and described in Official Record 341, Page 612, Tract I and all of the Melvin Sidesinger 7.25 acre tract as deeded and described in Official Record 341, Page 612, Tract II of the Logan County Records of Deeds and being more particularly described as follows:

Beginning at a railroad spike found at the intersection of the center-line of County Highway 5 and County Highway 29.

THENCE, with the center-line of County Highway 5 (60 feet wide), S 45°-17'-42" W, a distance of 116.19 feet to a 1 inch square iron bar found.

THENCE, continuing with the center-line of County Highway 5, S 28°-44'-51" W, a distance of 543.40 feet to a MAG nail set, passing a MAG nail set at 333.00 feet.

THENCE, with the north line of the Thomas W. Godwin 189.963 acre tract (O.R. 331, Pg. 195), N 61°-10'-28" W, a distance of 755.90 feet to a 5/8 inch iron rod set, passing a 5/8 inch iron rod found at 30.00 feet.

THENCE, with the lines of the State of Ohio original 14.22 acre tract, (Vol. 191, Pg. 454), the following two (2) courses:

N 7°-32'-43" E, a distance of 561.50 feet to a 5/8 inch iron rod set.

N 54°-57'-00" W, a distance of 412.60 feet to a 5/8 inch iron rod set.

THENCE, with the east line of the State of Ohio 2.06 acre tract (Vol. 288, Pg. 97), N 4°-12'-35" W, a distance of 414.74 feet to a 1 inch iron rod found, passing a 5/8 inch iron rod set at 384.74 feet.

THENCE, with the center-line of County Highway 29, the following three (3) courses:

N 85°-13'-15" E, a distance of 258.46 feet to a MAG nail set.

With a curve to the right having a central angle of 54°-51'-37", a radius of 320.00 feet, an arc length of 306.40 feet and having a chord bearing S 67°-20'-57" E, a distance of 294.83 feet to a MAG nail set.

S 39°-55'-08" E, a distance of 1201.50 feet to the point of beginning.

Containing 24.045 acres, of which 1.126 acres are within the highway rights-of-way.

The basis for bearings is the center-line of County Highway 5 at the point of beginning, being S 45°-17'-42" W, and all other bearings are from angles and distances measured in a field survey by Lee Surveying and Mapping Co., Inc. on September 17, 2001.

Description prepared by:



ORIGINAL STAMP IN GREEN

Jeffrey I. Lee
Jeffrey I. Lee
Professional Surveyor 6359
September 25, 2001

L-3221

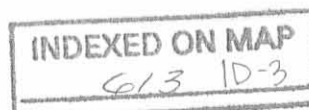

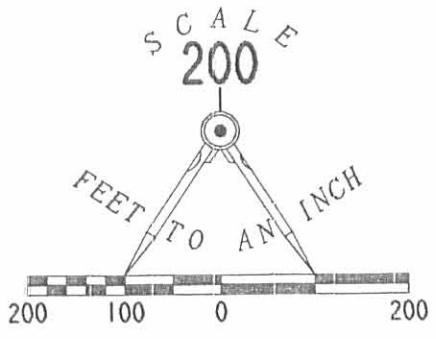

STEVEN R. FANSLER
111.67 ACRES
O.R. 139, PG. 830
PARCEL TWO

PAMELA K. HOOK, ETAL
73.634 ACRES
O.R. 437, PG. 242



LEGEND

- 5/8" IRON ROD SET
- ⊙ MAG NAIL SET
- 5/8" IRON ROD FOUND
- ⊕ 1" IRON ROD FOUND
- 1" SQUARE IRON BAR FOUND
- ⊗ 1" IRON PIPE FOUND
- ⊗ RAILROAD SPIKE FOUND

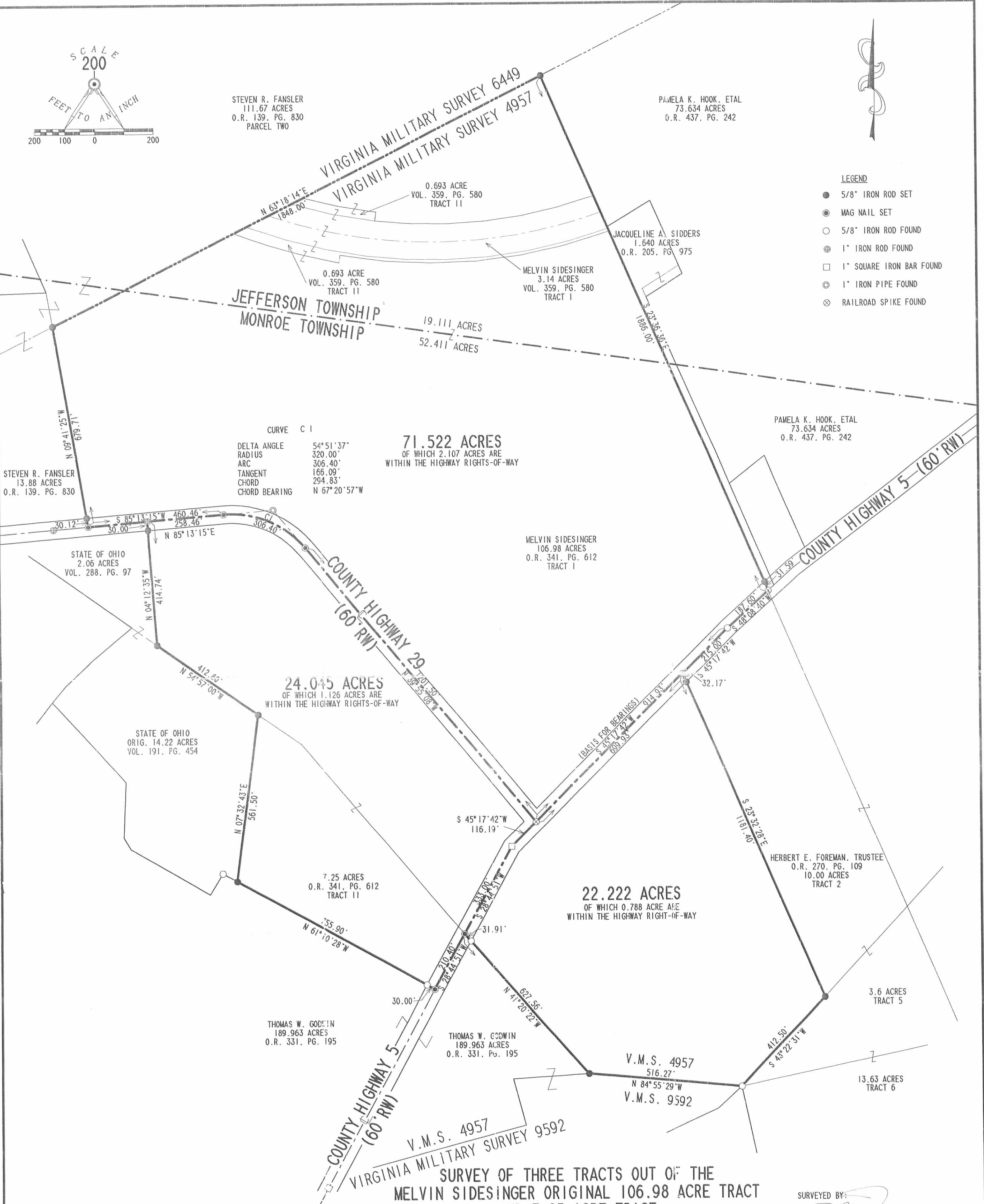

CURVE C 1

DELTA ANGLE	54° 51' 37"
RADIUS	320.00'
ARC	306.40'
TANGENT	166.09'
CHORD	294.83'
CHORD BEARING	N 67° 20' 57" W

71.522 ACRES
OF WHICH 2.107 ACRES ARE
WITHIN THE HIGHWAY RIGHTS-OF-WAY

24.045 ACRES
OF WHICH 1.126 ACRES ARE
WITHIN THE HIGHWAY RIGHTS-OF-WAY

22.222 ACRES
OF WHICH 0.788 ACRES ARE
WITHIN THE HIGHWAY RIGHT-OF-WAY

SURVEY OF THREE TRACTS OUT OF THE
MELVIN SIDESINGER ORIGINAL 106.98 ACRE TRACT
AND 7.25 ACRE TRACT
OFFICIAL RECORD 341, PAGE 612, TRACT 1 AND TRACT 2
AND THE MELVIN SIDESINGER 3.14 ACRE TRACT
AND 0.693 ACRE TRACT
VOLUME 359, PAGE 580, TRACT 1 AND TRACT 11
VIRGINIA MILITARY SURVEY 4957
JEFFERSON AND MONROE TOWNSHIPS
LOGAN COUNTY, OHIO

SURVEYED BY:



JEFFREY L. LEE
PROFESSIONAL SURVEYOR 6359
SEPTEMBER 17, 2001

COPYRIGHT 2001 BY:
LEE SURVEYING & MAPPING CO., INC.
117 North Madriver Street
BELLEFONTAINE, OHIO 43311
(937) 593-7335

ORIGINAL STAMP IN GREEN

D396 MSLIDE L-3221-2

2 WORKING DAYS
BEFORE YOU DIG
CALL TOLL FREE 800-362-2764
OHIO UTILITIES PROTECTION SERVICE.

INDEXED ON MAP
613 1P

Received 2-5-03 original

Lee Surveying and Mapping Co., Inc.

Land Surveys • Topography • Subdivisions • Construction Layout

117 N. Madriver St.
Bellefontaine OH 43311



Phone: (937) 593-7335
Fax: (937) 593-7444

PETTY 6.364 ACRES

Lying in Virginia Military Survey 4957, Monroe Township, Logan County, Ohio.

Being out of the Dorothy J. Petty and Janet K. Montgomery 24.045 acre tract as deeded and described in Official Record 524, Page 665, Tract I, of the Logan County Records of Deeds and being more particularly described as follows:

Beginning at a railroad spike found at the intersection of the center-lines of County Highway 5 and County Highway 29.

THENCE, with the center-line of County Highway 29, N 39°-55'-08" W, a distance of 1029.72 feet to a MAG nail set at the TRUE POINT OF BEGINNING.

THENCE, S 40°-23'-43" W, a distance of 301.60 feet to a 5/8 inch iron rod set, passing a 5/8 inch iron rod set at 30.43 feet.

THENCE, S 21°-08'-15" W, a distance of 211.35 feet to a 5/8 inch iron rod found.

THENCE, with a northerly line of the State of Ohio original 14.22 acre tract, (Vol. 191, Pg. 454), N 54°-57'-00" W, a distance of 412.60 feet to a 5/8 inch iron rod found.

THENCE, with the east line of the State of Ohio 2.06 acre tract (Vol. 288, Pg. 97), N 4°-12'-35" W, a distance of 414.74 feet to a 1 inch iron rod found, passing a 5/8 inch iron rod found at 384.74 feet.

THENCE, with the center-line of County Highway 29, the following three (3) courses:

N 85°-13'-15" E, a distance of 258.46 feet to a MAG nail found.

With a curve to the right having a central angle of 54°-51'-37", a radius of 320.00 feet, an arc length of 306.40 feet and having a chord bearing S 67°-20'-57" E, a distance of 294.83 feet to a MAG nail found.

S 39°-55'-08" E, a distance of 171.78 feet to the point of beginning.

Containing 6.364 acres, of which 0.499 acre is within the highway right-of-way.

The basis for bearings is the center-line of County Highway 5 at the point of beginning, being S 45°-17'-42" W, and all other bearings are from angles and distances measured in a field survey by Lee Surveying and Mapping Co., Inc. on September 17, 2001.

Description prepared by:



ORIGINAL STAMP IN GREEN

Jeffrey I. Lee
Professional Surveyor 6359
February 3, 2003

L-3221

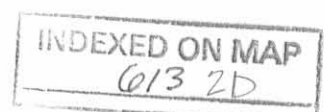

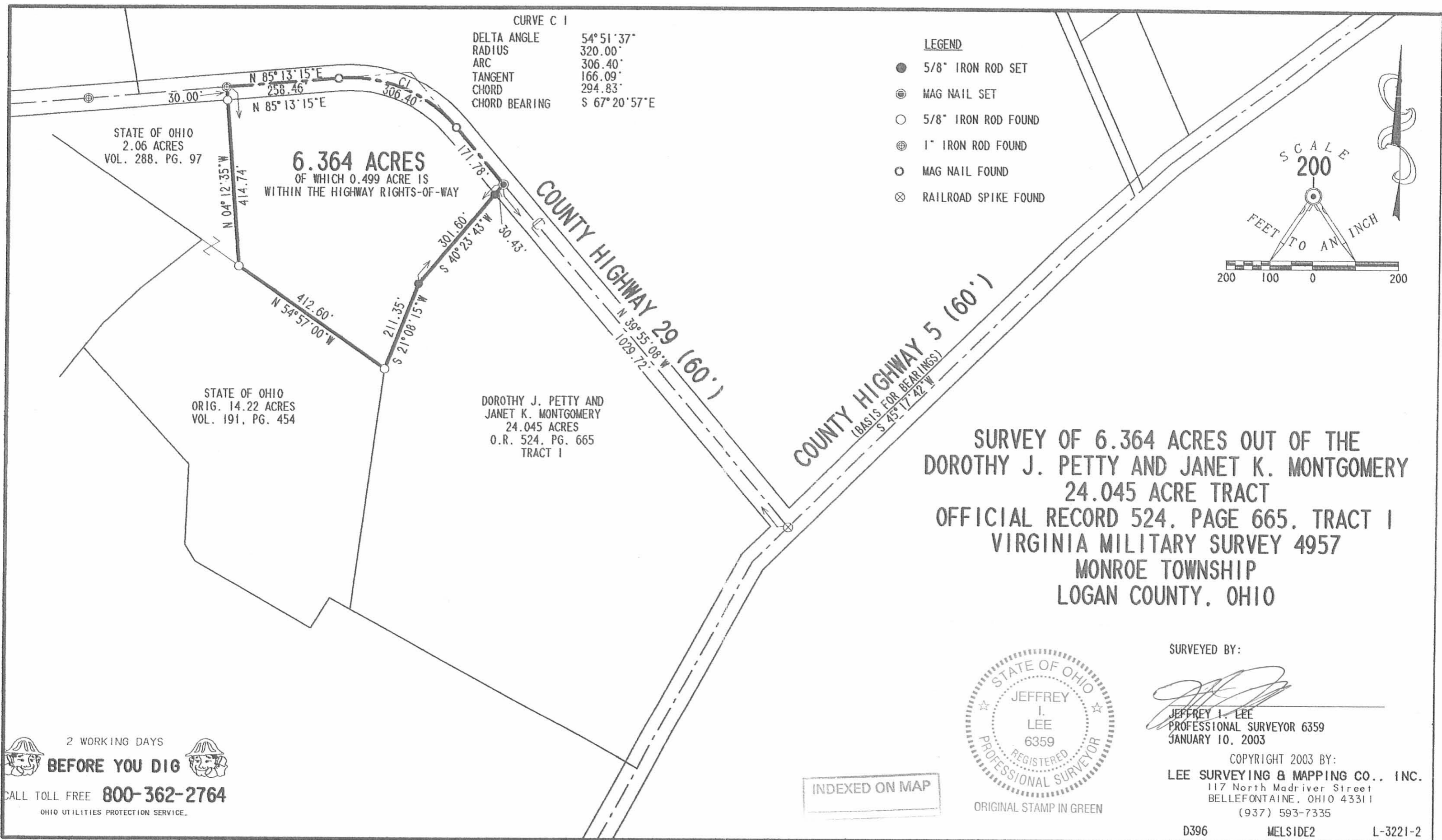

**SURVEY OF 6.364 ACRES OUT OF THE
 DOROTHY J. PETTY AND JANET K. MONTGOMERY
 24.045 ACRE TRACT
 OFFICIAL RECORD 524, PAGE 665, TRACT 1
 VIRGINIA MILITARY SURVEY 4957
 MONROE TOWNSHIP
 LOGAN COUNTY, OHIO**

SURVEYED BY:

Jeffrey I. Lee
 JEFFREY I. LEE
 PROFESSIONAL SURVEYOR 6359
 JANUARY 10, 2003



ORIGINAL STAMP IN GREEN

COPYRIGHT 2003 BY:
LEE SURVEYING & MAPPING CO., INC.
 117 North Madriver Street
 BELLEFONTAINE, OHIO 43311
 (937) 593-7335

INDEXED ON MAP

2 WORKING DAYS
BEFORE YOU DIG
 CALL TOLL FREE **800-362-2764**
 OHIO UTILITIES PROTECTION SERVICE.

INDEXED ON MAP
613 2P

D396 MELSIDE2 L-3221-2

Sidesinger Survey

July 1926

Monroe Township -- 3.6 acres

3

The following described land being in Virginia Military Survey 4957 and being in Monroe Township, Logan County, Ohio.

Beginning at a point in the center of Mad River where the line between Virginia Military Survey #4957 and Virginia Military Survey #9592 crosses said Mad River Creek, thence N. 84° - 43' E. along the South side of Virginia Military Survey #4957 - 626.4 feet to a post, thence N. 25° - 0' W. (making an interior angle of 70° - 17') 497.0 feet to a point in the center of Mad River Creek; thence with the center of Mad River in a South Westerly direction to the place of beginning, said tract containing three and six-tenths (3.6) acres more or less and being the same tract as surveyed by F.F. Wright July 24, 1926 and being recorded in Surveyor's field book # 418 page 24.

613 3D

RECID 1-15-09 SUMOK

Lee Surveying and Mapping Co., Inc.

Land Surveys • Topography • Subdivisions • Construction Layout

117 N. Madriver St.
Bellefontaine OH 43311



Phone: (937) 593-7335
Fax: (937) 593-7444

GODWIN 39.410 ACRES

Lying in Virginia Military Survey 4957, Jefferson and Monroe Townships, Logan County, Ohio.

Being out of the Richard A. Petty and Connie J. McNeal 71.522 acre tract as deeded and described in Official Record 835, Page 834, Tract III of the Logan County Records of Deeds and being more particularly described as follows:

Commencing on a railroad spike found on the intersection of the center-lines of County Highway 5 and County Highway 29.

THENCE, with the center-line of County Highway 29 (60 feet wide), the following two courses:

N 39°-55'-08"W, a distance of 1201.50 feet to a MAG nail found.

With a curve to the left, having a central angle of 34°-08'-28", a radius of 320.00 feet, an arc length of 190.68 feet, a chord bearing N 56°-59'-23"W, a distance of 187.87 feet to a MAG nail set at the TRUE POINT OF BEGINNING.

THENCE, with the center-line of County Highway 29, the following two courses:

With a curve to the left, having a central angle of 20°-43'-05", a radius of 320.00 feet, an arc length of 115.71 feet, a chord bearing N 84°-25'-11"W, a distance of 115.08 feet to a MAG nail found.

S 85°-13'-15"W, a distance of 460.46 feet to a MAG nail found.

THENCE, with the east line of the Larry Morris 4.256 acre tract (O.R. 774, Pg. 436, Tract I), N 09°-41'-25"W, a distance of 679.71 feet to a 5/8 inch iron rod found on the north line of Virginia Military Survey 4957, passing a 5/8 inch iron rod found at 30.12 feet.

THENCE, with the north line of Virginia Military Survey 4957 and the south line of the Larry Morris 111.072 acre tract (O.R. 774, Pg. 436, Tract III), N 63°-18'-14"E, a distance of 1848.00 feet to a 5/8 inch iron rod found.

THENCE, with the west lines of the Pamela K. Hook, et al, 73.634 acre tract (O.R. 437, Pg. 242) and the Jacqueline A. Sidders 1.640 acre tract (O.R. 205, Pg. 975), S 23°-36'-36"E, a distance of 1050.27 feet to a 5/8 inch iron rod set.

THENCE, S 78°-31'-52"W, a distance of 449.99 feet to a 5/8 inch iron rod set.

INDEXED ON MAP
6/13 HD-1

Lee Surveying and Mapping Co., Inc.

Land Surveys • Topography • Subdivisions • Construction Layout

117 N. Madriver St.
Bellefontaine OH 43311

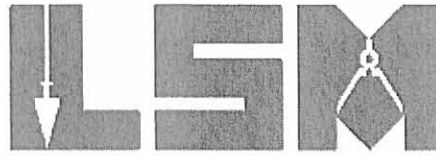

Phone: (937) 593-7335
Fax: (937) 593-7444

THENCE, S 68°-24'-37"W, a distance of 470.85 feet to a 5/8 inch iron rod set.

THENCE, S 63°-50'-48"W, a distance of 562.63 feet to the point of beginning, passing a 1 inch iron pipe found at 505.85 feet and a 5/8 inch iron rod set at 520.01 feet.

Containing 39.410 acres, of which 0.413 acre is within the highway right-of-way. There are 20.300 acres within Monroe Township and 19.110 acres within Jefferson Township.

The basis for bearings is the center-line of County Highway 5 north of the intersection of County Highway 29, being S 45°-17'-42"W, and all other bearings are from angles and distances measured in a field survey by Lee Surveying and Mapping Co., Inc. on December 23, 2008.



ORIGINAL STAMP IN GREEN

Description prepared by:

A handwritten signature in cursive script that reads 'William K. Bruce'.

William K. Bruce
Professional Surveyor 7437
December 30, 2008

3221128

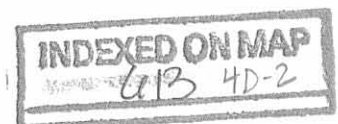

REV'D 1-15-09 SMY/OL

CURVE	DELTA ANGLE	RADIUS	ARC LENGTH	CHORD BEARING	CHORD LENGTH
C1	34°08'28"	320.00'	190.68'	N 56°59'23" W	187.87'
C2	20°43'05"	320.00'	115.71'	N 84°25'11" W	115.08'

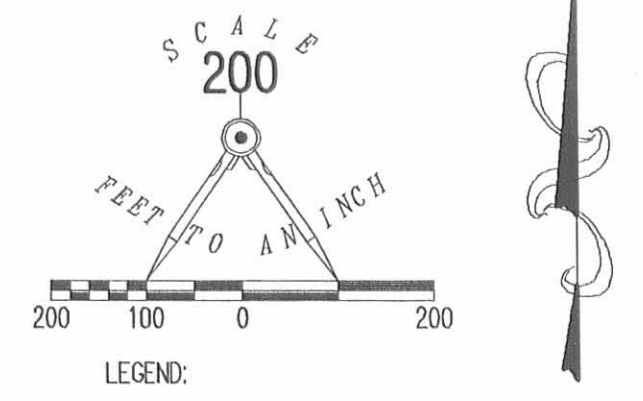

- LEGEND:
- 5/8 INCH IRON ROD FOUND
 - 5/8 INCH IRON ROD SET
 - ⊗ RAILROAD SPIKE FOUND
 - ⊗ MAG NAIL FOUND
 - ⊙ MAG NAIL SET
 - ⊕ 1 INCH IRON ROD FOUND
 - ⊕ 1 INCH IRON PIPE FOUND

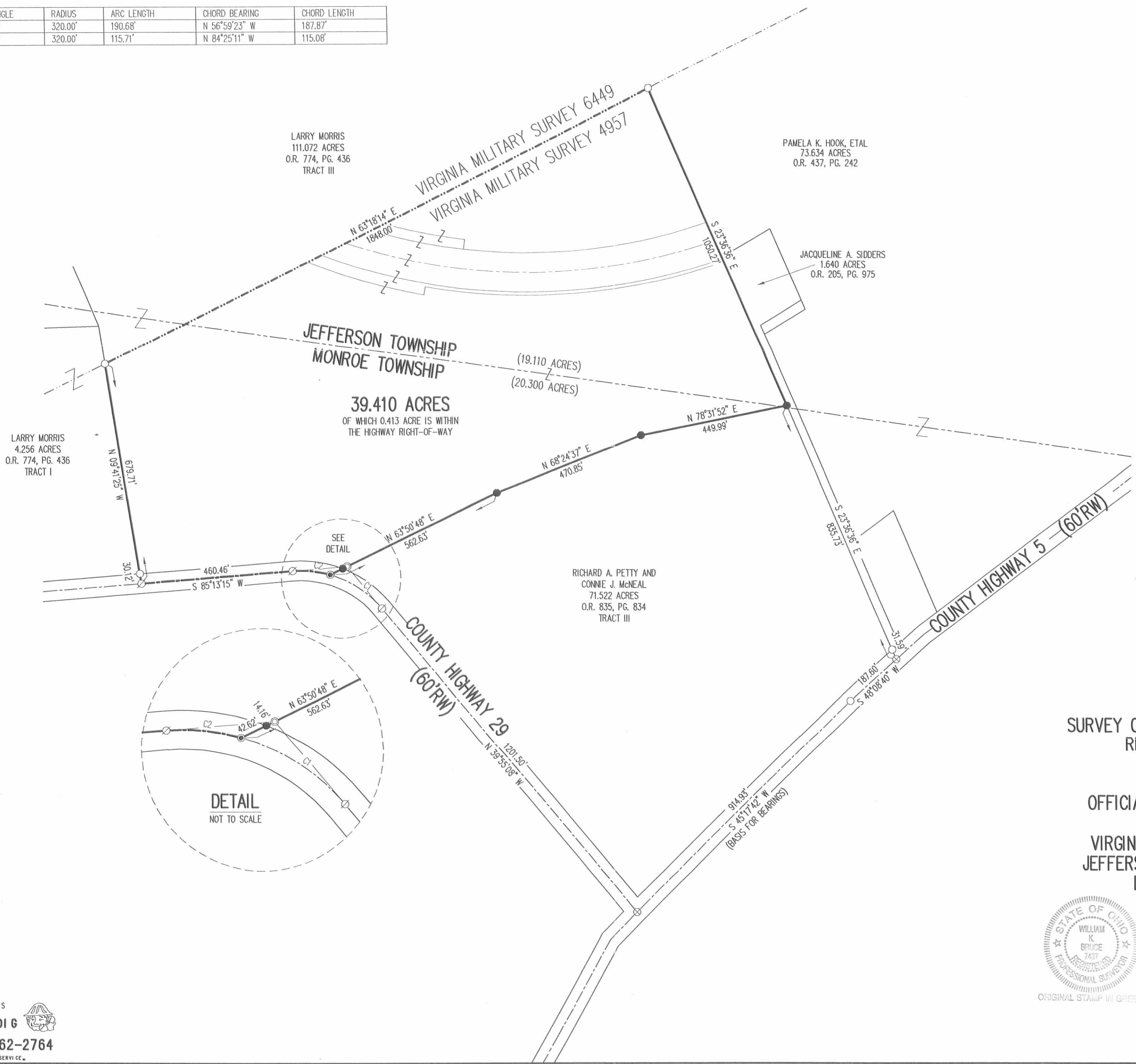

SURVEY OF 39.410 ACRES OUT OF THE
RICHARD A. PETTY AND
CONNIE J. McNEAL
71.522 ACRE TRACT
OFFICIAL RECORD 835, PAGE 834
TRACT III
VIRGINIA MILITARY SURVEY 4957
JEFFERSON AND MONROE TOWNSHIP
LOGAN COUNTY, OHIO



SURVEYED BY:
William K. Bruce
WILLIAM K. BRUCE
PROFESSIONAL SURVEYOR 7437
DECEMBER 23, 2008

COPYRIGHT 2008 BY:
LEE SURVEYING & MAPPING CO., INC.
117 North Madriver Street
BELLEFONTAINE, OHIO 43311
(937) 593-7335
surveys@lsmcinc.us
KSS D1208 3221128 L-3221-2

2 WORKING DAYS
BEFORE YOU DIG
CALL TOLL FREE 800-362-2764
OHIO UTILITIES PROTECTION SERVICE

INDEXED ON MAP
613 4P