

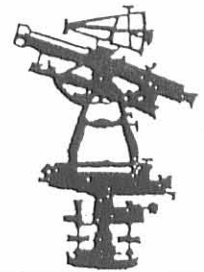

**EDWARDS SURVEYING**  
110 SOUTH MAIN STREET  
URBANA, OHIO 43078  
(937) 653-6508



**LEGAL DESCRIPTION FOR WEEKS 2.225 ACRE TRACT**

Being situate in the State of Ohio, County of Logan, Township of Miami and being a part of the Northwest quarter of Section 4, Town 3, Range 13, B.T.M.R.S., and being more particularly described as follows;

Beginning for reference at a railroad spike found at the intersection of the centerlines of Township Road 295 (60' right-of-way) and County Road 65 (60' right-of-way);

thence with the centerline of County Road 65, N-6°00'00"-E, 2205.02' (feet) to a Mag nail set at the PRINCIPLE PLACE OF BEGINNING for the tract hereinafter described;

thence N-85°33'38"-W, 821.39' (feet) to an iron bar set, passing for reference an iron bar set on the right-of-way line of County Road 65 at 30.01' (feet);

thence with the approximate centerline of a creek, N-29°54'59"-E, 241.21' (feet) to a point;

thence S-84°11'17"-E, 320.78' (feet) to an iron bar set, passing for reference an iron bar set at 30.00' (feet);

thence S-12°27'21"-E, 187.13' (feet) to an iron bar set;

thence S-85°23'18"-E, 343.38' (feet) to a Mag nail set on the centerline of aforementioned County Road 65, passing for reference an iron bar set on the right-of-way line of County Road 65 at 313.37' (feet);

thence with the centerline of County Road 65, S-6°00'00"-W, 30.00' (feet) to the place of beginning.

Containing 2.225 acres, 0.021 acre of which is within the road right-of-way, but being subject to the rights of all legal highways and all easements of record.

Being a part of a 40 acre tract conveyed to Mary J. Weeks, Trustee, by Deed recorded in Official Record 628, Page 225, Tract IV, of the Logan County Records.

The foregoing description prepared by and in accordance with a Survey by William D. Edwards, Professional Surveyor No. 7574, December 1, 2004. All iron bars set are 5/8"x30" iron re-bar with a yellow plastic cap stamped "EDWARDS PS 4792 PS 7574". The basis of bearings for the herein described tract is the centerline of County Road 65 per an assumed bearing of N-6°00'00"-E.



William D. Edwards  
Professional Surveyor No. 7574





DEED 12-6-04 S.M.J. OK

**EDWARDS SURVEYING**  
110 SOUTH MAIN STREET  
URBANA, OHIO 43078  
(937) 653-6508

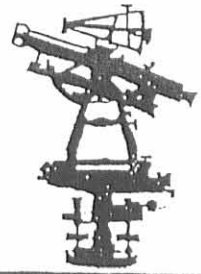

**LEGAL DESCRIPTION FOR WEEKS INGRESS/EGRESS EASEMENT**

Being situate in the State of Ohio, County of Logan, Township of Miami and being a part of the Northwest quarter of Section 4, Town 3, Range 13, B.T.M.R.S., and being an easement, 15.00' (feet) in width, for ingress and egress, said easement and being more particularly described as follows;

Beginning for reference at a railroad spike found at the intersection of the centerlines of Township Road 295 (60' right-of-way) and County Road 65 (60' right-of-way);

thence with the centerline of County Road 65, N-6°00'00"-E, 2190.01' (feet) to a point at the PRINCIPLE PLACE OF BEGINNING for the easement hereinafter described;

thence N-85°33'38"-W, 820.98' (feet) to a point, passing for reference the right-of-way line of County Road 65 at 30.01' (feet);

thence N-4°26'22"-E, 15.00' (feet) to an iron bar set;

thence S-85°33'38"-E, 821.39' (feet) to a Mag nail set on the centerline of aforementioned County Road 65, passing for reference an iron bar set on the right-of-way line of County Road 65 at 791.38' (feet);

thence with the centerline of County Road 65, S-6°00'00"-W, 15.01' (feet) to the place of beginning.

Containing 0.283 acre, but being subject to the rights of all legal highways and all easements of record.

Being a part of a 40 acre tract conveyed to Mary J. Weeks, Trustee, by Deed recorded in Official Record 628, Page 225, Tract IV, of the Logan County Records.

The foregoing description prepared by and in accordance with a Survey by William D. Edwards, Professional Surveyor No. 7574, December 1, 2004. All iron bars set are 5/8"x30" iron re-bar with a yellow plastic cap stamped "EDWARDS PS 4792 PS 7574". The basis of bearings for the herein described tract is the centerline of County Road 65 per an assumed bearing of N-6°00'00"-E.



*William D. Edwards*  
William D. Edwards  
Professional Surveyor No. 7574

INDEXED ON MAP  
41241D-2

REC'D 12-6-04 S.M.J.

# PLAT OF SURVEY

MIAMI TOWNSHIP, LOGAN COUNTY, OHIO  
SECTION 4, TOWN 3, RANGE 13, B.T.M.R.S..

SCALE: 1" = 60'  
DATE: DECEMBER 1, 2004



**2.225 AC.**  
(0.021 AC. R/W)  
(2.204 AC. NET)

MARY J. WEEKS, TRUSTEE  
PT. 40 AC.  
PT. O.R. 628, P. 225  
TRACT IV

MARY J. WEEKS, TRUSTEE  
40 AC.  
PT. O.R. 628, P. 225  
TRACT IV

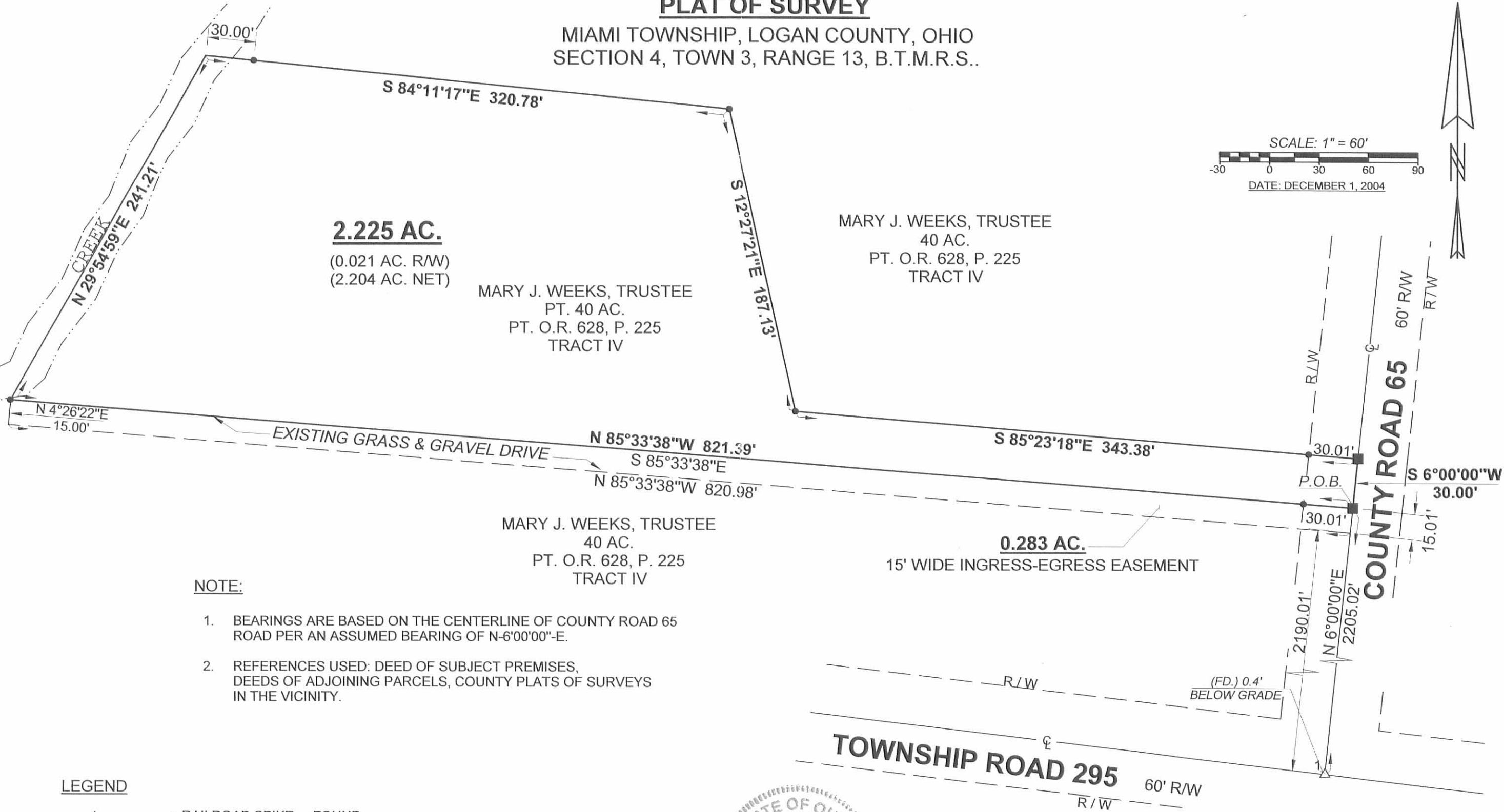

**NOTE:**

1. BEARINGS ARE BASED ON THE CENTERLINE OF COUNTY ROAD 65 ROAD PER AN ASSUMED BEARING OF N-6°00'00"-E.
2. REFERENCES USED: DEED OF SUBJECT PREMISES, DEEDS OF ADJOINING PARCELS, COUNTY PLATS OF SURVEYS IN THE VICINITY.

**LEGEND**

- △ = RAILROAD SPIKE.....FOUND
- = MAG NAIL.....SET at grade
- = 5/8"x30" IRON RE-BAR WITH YELLOW PLASTIC CAP STAMPED "EDWARDS PS 4792 PS 7574".....SET at grade



SURVEYED BY:

WILLIAM D. EDWARDS  
PROFESSIONAL SURVEYOR No. 7574  
110 SOUTH MAIN STREET  
URBANA, OHIO 43078  
(937)653-6508

INDEXED ON MAP  
4124 1P

Description For Stella Foulk  
Miami Township  
Logan County, Ohio

The Following Described Real Estate:

Situated in the State of Ohio, County of Logan and in the Township of Miami, bounded and described as follows:

TRACT ONE: Being the North Half of the Northeast Quarter of Section 10, Town 3, Range 13, containing 80.00 Ac. more or less, excepting from the above described real estate, 0.72 Ac. in the name of Hobson Black as recorded in Deed Vol. 303 Page 80 (6-8-65) and also excepting from the above described real estate, 17.50 Ac. in the name of John D. Baughman etax as recorded in Deed Vol. 302 Page 410 (5-12-65), leaving after exceptions, 61.78 Ac. more or less.

TRACT TWO: Being the Northwest Quarter of the Northwest Quarter of Section 4, Town 3, Range 13, containing 40.00 Ac. more or less.

Total Acreage for both tracts being 101.78 Ac. more or less, with 61.78 Ac. being in Section 10 and 40.00 Ac. more or less, being in Section 4.

This description prepared by Daniel E. Gilbert, Registered Surveyor No. 5402 on September 1, 1967.

4126

2D

INDEXED ON MAP

# Lee Surveying and Mapping Co., Inc.

Land Surveys • Topography • Subdivisions • Construction Layout

117 N. Madriver St.  
Bellefontaine OH 43311



Phone: (937) 593-7335  
Fax: (937) 593-7444  
surveys@lsminc.us

## WEEKS 136.349 ACRES

Lying in Section 10 and 11, Town 3, Range 13, Miami Township, Logan County, Ohio.

Being all of the Mary J. Weeks, Trustee 129.884 acre tract as deeded and described in Official Record 628, Page 225, Tract V of the Logan County Records of Deeds and being more particularly described as follows:

Beginning on a stone found in a monument box on the northwest corner of the northeast quarter of Section 10 on the center-line of County Highway 64.

THENCE, with the north lines of Section 10 and the south line of the Cynthia Sue Parcels, Successor Trustee, 143.75 acre tract (O.R. 412, Pg. 75, Tract II) and the Bruce E. Weeks et al, 21.25 acre tract (Vol. 408, Pg. 860, Tract II), N 89°-49'-33"E, a distance of 2625.08 feet to a stone found at the northeast corner of Section 10, passing a 5/8 inch iron rod set at 30.00 feet.

THENCE, with the east line of Section 10 and the west line of the Mary J. Weeks, Trustee 40.00 acre tract (O.R. 628, Pg. 225, Tract IV), S 01°-05'-04"E, a distance of 1355.86 feet to a 5/8 inch iron rod set.

THENCE, with the north line of the Philip C. Weeks 198.20 acre tract (O.R. 873, Pg. 126, Tract II), S 89°-41'-27"W, a distance of 780.64 feet to a 5/8 inch iron rod set.

THENCE, with the lines of the William E. Moore, Trustee 17 1/2 acre tract (O.R. 405, Pg. 526, Tract I), the following two courses:

N 00°-26'-41"W, a distance of 420.09 feet to a 5/8 inch iron rod set.

S 89°-28'-39"W, a distance of 1694.05 feet to a 5/8 inch iron rod set.

THENCE, with the east line of the Orville Tussing 0.216 acre tract (Vol. 371, Pg. 855, Tract I), N 00°-26'-41"W, a distance of 188.50 feet to a 5/8 inch iron rod set.

THENCE, with the north lines of the said 0.216 acre tract and the Orville Tussing 1/2 acre tract (Vol. 371, Pg. 855, Tract II), S 89°-28'-39"W, a distance of 165.50 feet to a MAG nail set on the center-line of County Highway 64 and the west line of the northeast quarter of Section 10, passing a 5/8 inch iron rod set at 135.50 feet.

THENCE, with the center-line of County Highway 64 (60 feet wide) and the west line of the northeast quarter of Section 10, S 00°-26'-41"E, a distance of 176.67 feet to a MAG nail set.

THENCE, with the north line of the William E. Moore, Trustee, 12.96 acre tract (O.R. 405, Pg. 526), N 89°-40'-22"W, a distance of 1328.42 feet to a 5/8 inch iron rod set, passing a 5/8 inch iron rod set at 30.00 feet.

THENCE, with an east line of the aforesaid 198.20 acre tract, N 00°-43'-09"W, a distance of 947.08 feet to a 1.25 feet diameter old metal post found filled with concrete on the north line of Section 10 and the south line of Section 11.

THENCE, with the east lines of the Lyn A. Davidson 25.067 acre tract (O.R. 766, Pg. 847, Tract One) and the Stephen R. Bowman 13.687 acre tract (O.R. 366, Pg. 753), N 00°-16'-42"E, a distance of 1397.76 feet to a 5/8 inch iron rod found.

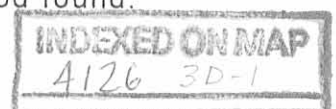

# Lee Surveying and Mapping Co., Inc.

Land Surveys • Topography • Subdivisions • Construction Layout

117 N. Madriver St.  
Bellefontaine OH 43311



Phone: (937) 593-7335  
Fax: (937) 593-7444  
surveys@lsminc.us

THENCE, with the south line of the Philip C. Weeks 29.35 acre tract (O.R. 943, Pg. 24), N 87°-06'-21"E, a distance of 1327.92 feet to a MAG nail set on the center-line of County Highway 64 and the east line of the southwest quarter of Section 11, passing a 1.25 feet diameter old metal post found filled with concrete at 1297.28 feet and a 5/8 inch iron rod set at 1298.88 feet.

THENCE, with the center-line of County Highway 64 and the east line of the southwest quarter of Section 11, S 00°-00'-00"E, a distance of 1482.49 feet to the point of beginning.

Containing 136.349 acres, of which 2.189 acres are within the highway right-of-way. There are 92.393 acres in Section 10 and 43.956 acres in Section 11.

The basis for bearings is east line of the southwest quarter of Section 11, being S 00°-00'-00"E, and all other bearings are from angles and distances measured in a field survey by Lee Surveying and Mapping Co., Inc. on June 26, 2009.



ORIGINAL STAMP IN GREEN

Description prepared by:

A handwritten signature in black ink that reads 'William K. Bruce'.

William K. Bruce  
Professional Surveyor 7437  
July 6, 2009

4807069

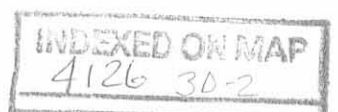

RED 7-16-09 JB OK

TOWNSHIP ROAD 71

TOWNSHIP ROAD 72

COUNTY HIGHWAY 64 (60')

TOWNSHIP ROAD 295

STEPHEN R. BOWMAN  
13.687 ACRES  
O.R. 366, PG. 753

PHILIP C. WEEKS  
29.35 ACRES  
O.R. 943, PG. 24

LYN A. DAVIDSON  
25.067 ACRES  
O.R. 766, PG. 847  
TRACT ONE

CYNTHIA SUE PARCELS, SUCCESSOR TRUSTEE  
143.75 ACRES  
O.R. 412, PG. 75  
TRACT II

BRUCE E. WEEKS ETAL  
21.25 ACRES  
VOL. 408, PG. 860  
TRACT II

BRUCE E. WEEKS ETAL  
75.80 ACRES  
VOL. 408, PG. 860  
TRACT I

136.349 ACRES  
OF WHICH 2.189 ACRES ARE WITHIN  
THE HIGHWAY RIGHT-OF-WAY

MARY J. WEEKS, TRUSTEE  
129.884 ACRES  
O.R. 628, PG. 225  
TRACT V

MARY J. WEEKS, TRUSTEE  
40.00 ACRES  
O.R. 628, PG. 225  
TRACT IV

RETRACEMENT SURVEY OF THE  
MARY J. WEEKS, TRUSTEE  
129.884 ACRE TRACT  
OFFICIAL RECORD 628, PAGE 225  
TRACT V  
SECTION 10, TOWN 3, RANGE 13  
SECTION 11, TOWN 3, RANGE 13  
MIAMI TOWNSHIP  
LOGAN COUNTY, OHIO

PHILIP C. WEEKS  
198.20 ACRES  
O.R. 873, PG. 126  
TRACT II

WILLIAM E. MOORE, TRUSTEE  
12.96 ACRES  
O.R. 405, PG. 526

WILLIAM E. MOORE, TRUSTEE  
17 1/2 ACRES  
O.R. 405, PG. 526  
TRACT I

PHILIP C. WEEKS  
198.20 ACRES  
O.R. 873, PG. 126  
TRACT II

PHILIP C. WEEKS  
15 ACRES  
O.R. 873, PG. 126  
TRACT III

SURVEYED BY:

*William K. Bruce*  
WILLIAM K. BRUCE  
PROFESSIONAL SURVEYOR 7437  
JUNE 26, 2009

COPYRIGHT 2009 BY: LEE SURVEYING & MAPPING CO., INC.  
117 North Madriver Street  
BELLEFONTAINE, OHIO 43311  
(937) 593-7335  
surveys@lsminc.us  
KSS D0609 4807069 L-4807-2

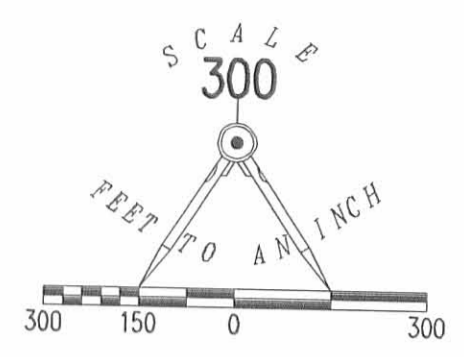

- LEGEND:
- ☒ STONE FOUND IN MONUMENT BOX
  - ⊙ BOAT SPIKE FOUND
  - ⊕ STONE FOUND
  - MAG NAIL SET
  - ⊙ 1.25 FEET DIAMETER OLD METAL POST FOUND FILLED WITH CONCRETE
  - 5/8 INCH IRON ROD FOUND
  - 5/8 INCH IRON ROD SET

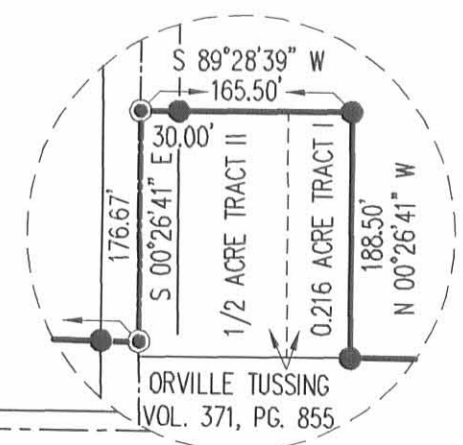
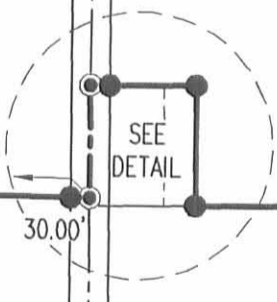
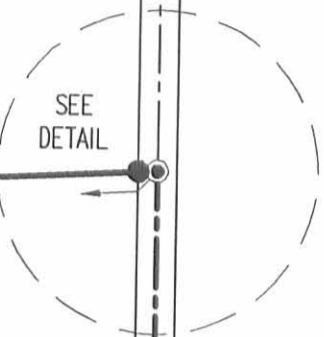
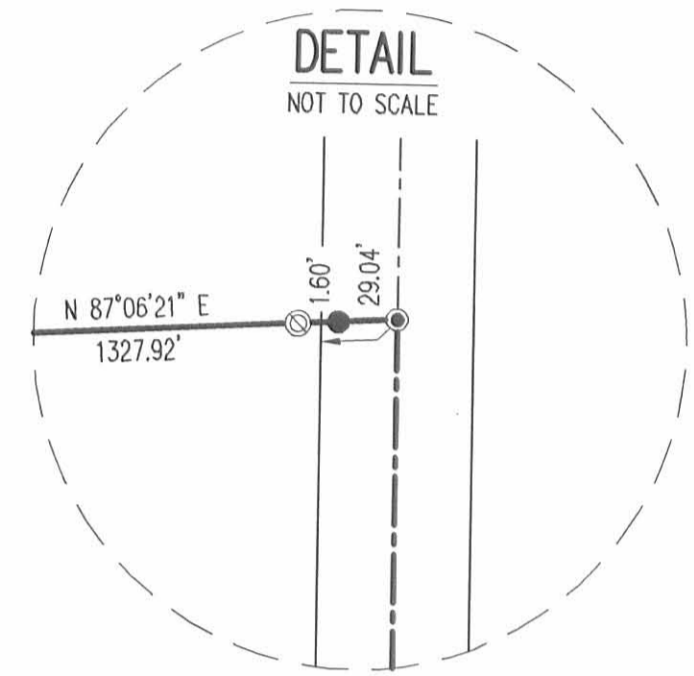

2 WORKING DAYS  
BEFORE YOU DIG  
CALL TOLL FREE 800-362-2764  
OHIO UTILITIES PROTECTION SERVICE

INDEXED ON MAP  
4126 3P

# Lee Surveying and Mapping Co., Inc.



Land Surveys • Topography • Subdivisions • Construction Layout

117 N. Madriver St.  
Bellefontaine OH 43311



Phone: (937) 593-7335  
Fax: (937) 593-7444  
surveys@lsminc.us

## MOORE 0.190 ACRE

Lying in Section 10, Town 3, Range 13, Miami Township, Logan County, Ohio.

Being out of the William E. Moore and Sandra E. Moore, as Trustees 17 ½ acre tract as deeded and described in Official Record 405, Page 526, Tract I of the Logan County Records of Deeds and being more particularly described as follows:

Commencing on a stone found in a monument box on the center of Section 10 on the intersection of the center-lines of Township Road 295 and County Highway 64.

THENCE, with the west line of the northeast quarter of Section 10 and the center-line of County Highway 64 (60 feet wide), N 00°-26'-41"W, a distance of 1361.91 feet to a railroad spike found on the southwest corner of the northwest quarter of the northeast quarter of Section 10 at the TRUE POINT OF BEGINNING.

THENCE, N 89°-21'-33"E, a distance of 426.07 feet to a 5/8 inch iron rod set, passing a point on the east right-of-way of County Highway 64 at 30.00 feet, referenced by a 5/8 inch iron rod found bearing S 00°-26'-41"E, a distance of 0.17 feet.

THENCE, N 89°-27'-20"E, a distance of 1433.48 feet to a 5/8 inch iron rod set.

THENCE, with a west line of the Bruce E. Weeks 136.349 acre tract (O.R. 974, Pg. 19, Tract III), S 00°-26'-41"E, a distance of 8.35 feet to a 5/8 inch iron rod found on the south line of the northwest quarter of the northeast quarter of Section 10.

THENCE, with the south line of the northwest quarter of the northeast quarter of Section 10 and the north line of the Philip C. Weeks 198.20 acre tract (O.R. 873, Pg. 126, Tract II), S 89°-41'-27"W, a distance of 1859.55 feet to the point of beginning, passing a 5/8 inch iron rod found at 1829.55 feet.

Containing 0.190 acre.

Property is subject to any and all previous easements and rights-of-way of record.

This parcel is to be attached to an adjoining tract of land and is not to be used as a separate and independent parcel.

The basis for bearings is the west line of the northeast quarter of Section 10, being N 00°-26'-41"W, and all other bearings are from angles and distances measured in a field survey by Lee Surveying and Mapping Co., Inc. on May 7, 2015.

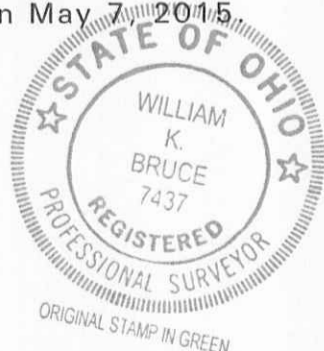

Description prepared by:

*William K. Bruce*  
William K. Bruce  
Professional Surveyor 7437  
May 13, 2015

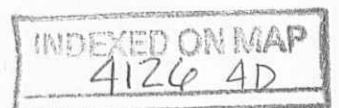

48070415



APPROVED

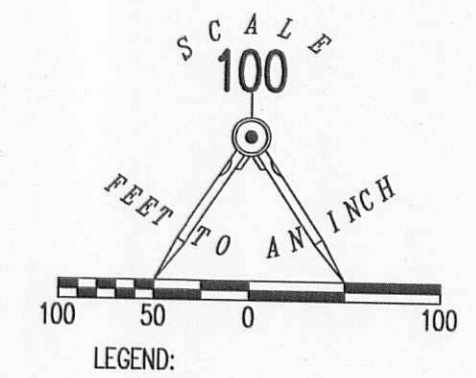

- LEGEND:
- ☒ STONE FOUND IN MONUMENT BOX
  - ⊗ RAILROAD SPIKE FOUND
  - 5/8 INCH IRON ROD FOUND
  - 5/8 INCH IRON ROD SET WITH PLASTIC I.D. CAP STAMPED "LSM 7437"

BRUCE E. WEEKS  
136.349 ACRES  
O.R. 974, PG. 19  
TRACT III

WILLIAM E. MOORE AND  
SANDRA E. MOORE, AS TRUSTEES  
17 1/2 ACRES  
O.R. 405, PG. 526  
TRACT I

PHILIP C. WEEKS  
198.20 ACRES  
O.R. 873, PG. 126  
TRACT II

COUNTY HIGHWAY 64 (60')

QUARTER SECTION LINE

SEE  
DETAIL

N 89°21'33" E 426.07'

0.190 ACRE

N 89°27'20" E 1433.48'

S 00°26'41" E  
8.35'

S 89°41'27" W 1859.55'

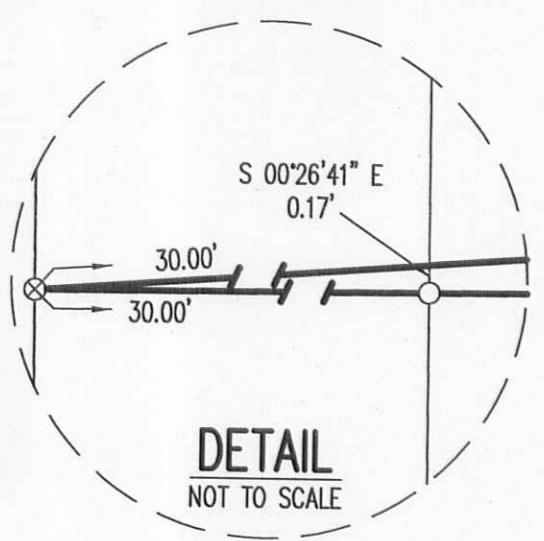

(BASIS FOR BEARINGS)  
N 00°26'41" W  
1361.91'

TOWNSHIP ROAD 295

CENTER OF SECTION 10

QUARTER SECTION LINE

SURVEY OF 0.190 ACRE OUT OF THE  
WILLIAM E. MOORE AND  
SANDRA E. MOORE, AS TRUSTEES  
17 1/2 ACRE TRACT  
OFFICIAL RECORD 405, PAGE 526  
TRACT I  
SECTION 10, TOWN 3, RANGE 13  
MIAMI TOWNSHIP  
LOGAN COUNTY, OHIO  
SURVEYED BY:

*William K. Bruce*



WILLIAM K. BRUCE  
PROFESSIONAL SURVEYOR 7437  
MAY 7, 2015

COPYRIGHT 2015 BY:  
LEE SURVEYING & MAPPING CO., INC.  
117 North Madriver Street  
BELLEFONTAINE, OHIO 43311  
(937) 593-7335  
WWW.LSMINC.US  
surveys@lsminc.us  
KSS D0415 48070415 L-4807-2

**NOTE:**  
THIS PARCEL IS TO BE ATTACHED TO AN ADJOINING TRACT  
OF LAND AND IS NOT TO BE USED AS A SEPARATE AND  
INDEPENDENT PARCEL.

2 WORKING DAYS  
**BEFORE YOU DIG**  
CALL TOLL FREE **800-362-2764**  
OHIO UTILITIES PROTECTION SERVICE

INDEXED ON MAP  
4126 4P

# PLAT OF SURVEY

MIAMI TOWNSHIP, LOGAN COUNTY, OHIO  
 N.E. 1/4, SECTION 10, TOWN 3, RANGE 13, B.T.M.R.S.

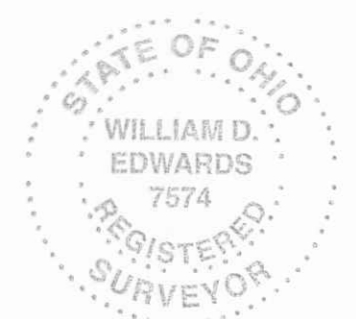
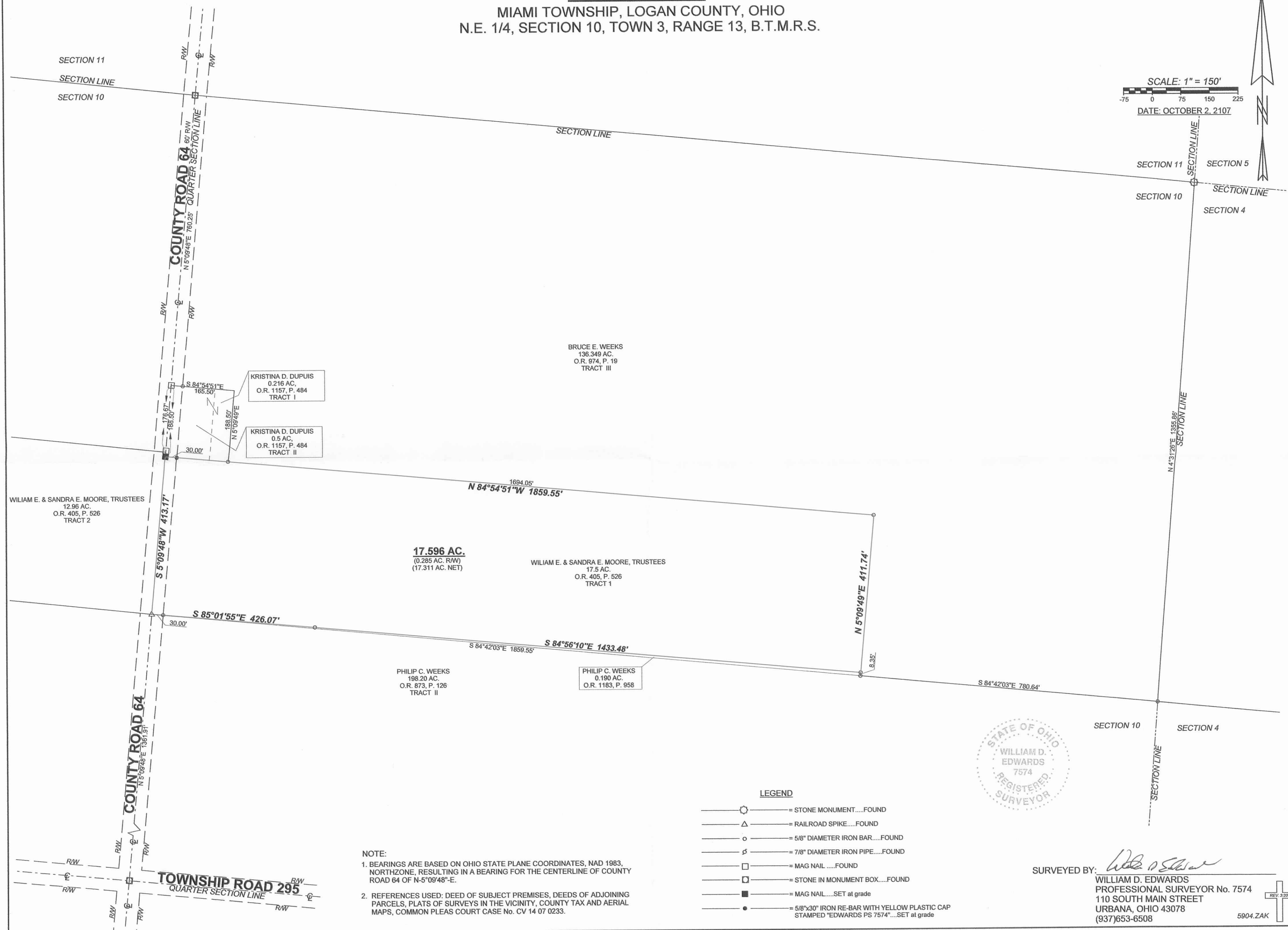
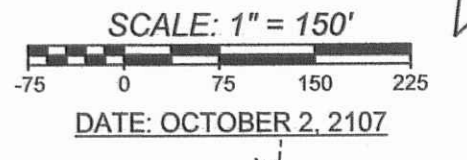

- LEGEND**
- = STONE MONUMENT.....FOUND
  - = RAILROAD SPIKE.....FOUND
  - = 5/8" DIAMETER IRON BAR.....FOUND
  - = 7/8" DIAMETER IRON PIPE.....FOUND
  - = MAG NAIL.....FOUND
  - = STONE IN MONUMENT BOX.....FOUND
  - = MAG NAIL.....SET at grade
  - = 5/8" x 30" IRON RE-BAR WITH YELLOW PLASTIC CAP STAMPED "EDWARDS PS 7574".....SET at grade

**NOTE:**

- BEARINGS ARE BASED ON OHIO STATE PLANE COORDINATES, NAD 1983, NORTHZONE, RESULTING IN A BEARING FOR THE CENTERLINE OF COUNTY ROAD 64 OF N-5°09'48"-E.
- REFERENCES USED: DEED OF SUBJECT PREMISES, DEEDS OF ADJOINING PARCELS, PLATS OF SURVEYS IN THE VICINITY, COUNTY TAX AND AERIAL MAPS, COMMON PLEAS COURT CASE No. CV 14 07 0233.

SURVEYED BY:

**WILLIAM D. EDWARDS**  
 PROFESSIONAL SURVEYOR No. 7574  
 110 SOUTH MAIN STREET  
 URBANA, OHIO 43078  
 (937)653-6508

5-21-2021

**APPROVED**

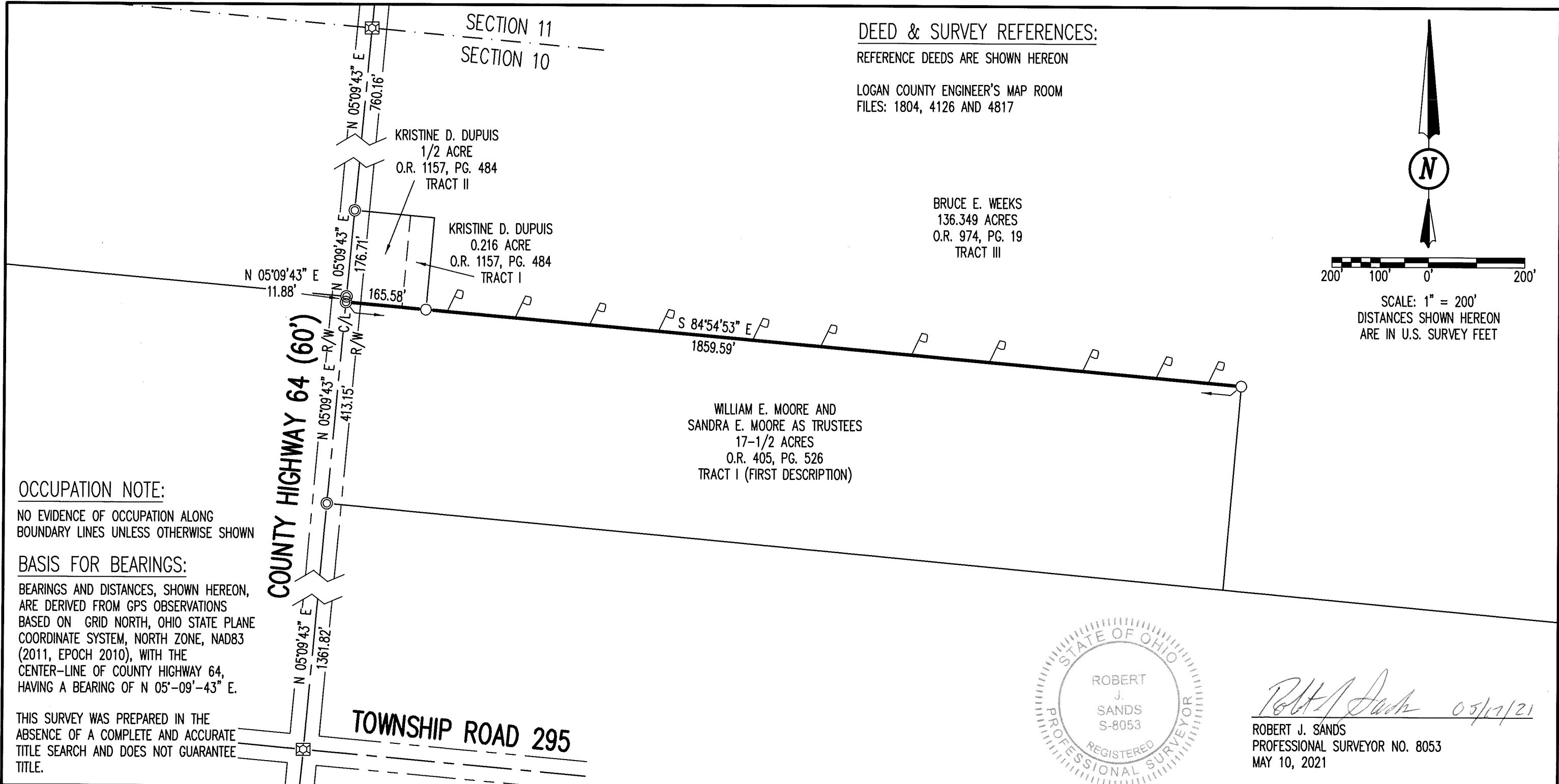

**DEED & SURVEY REFERENCES:**

REFERENCE DEEDS ARE SHOWN HEREON  
 LOGAN COUNTY ENGINEER'S MAP ROOM  
 FILES: 1804, 4126 AND 4817

BRUCE E. WEEKS  
 136.349 ACRES  
 O.R. 974, PG. 19  
 TRACT III

WILLIAM E. MOORE AND  
 SANDRA E. MOORE AS TRUSTEES  
 17-1/2 ACRES  
 O.R. 405, PG. 526  
 TRACT I (FIRST DESCRIPTION)

KRISTINE D. DUPUIS  
 1/2 ACRE  
 O.R. 1157, PG. 484  
 TRACT II

KRISTINE D. DUPUIS  
 0.216 ACRE  
 O.R. 1157, PG. 484  
 TRACT I

**OCCUPATION NOTE:**

NO EVIDENCE OF OCCUPATION ALONG  
 BOUNDARY LINES UNLESS OTHERWISE SHOWN

**BASIS FOR BEARINGS:**

BEARINGS AND DISTANCES, SHOWN HEREON,  
 ARE DERIVED FROM GPS OBSERVATIONS  
 BASED ON GRID NORTH, OHIO STATE PLANE  
 COORDINATE SYSTEM, NORTH ZONE, NAD83  
 (2011, EPOCH 2010), WITH THE  
 CENTER-LINE OF COUNTY HIGHWAY 64,  
 HAVING A BEARING OF N 05'-09'-43" E.

THIS SURVEY WAS PREPARED IN THE  
 ABSENCE OF A COMPLETE AND ACCURATE  
 TITLE SEARCH AND DOES NOT GUARANTEE  
 TITLE.

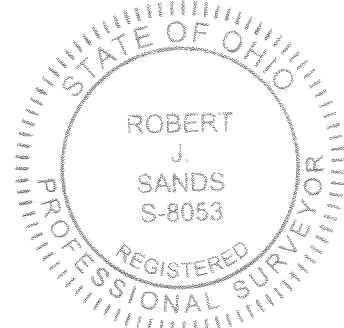

*Robert J. Sands* 05/17/21

ROBERT J. SANDS  
 PROFESSIONAL SURVEYOR NO. 8053  
 MAY 10, 2021

COPYRIGHT 2021 BY:

117 N. Madriver Street • Bellefontaine, OH 43311  
 (937) 593-7335 • www.dlz.com  
 Project #2121-2064.00

**LEGEND**

|   |   |
|---|---|
| STONE FOUND IN MONUMENT BOX                                       | WOOD LATH SET ON LINE   |
| 5/8 INCH IRON REBAR FOUND WITH PLASTIC I.D. CAP STAMPED "PS 7437" | R/W = RIGHT-OF-WAY<br>C/L = CENTER-LINE<br>O.R. = OFFICIAL RECORD<br>PG. = PAGE |
| MAG NAIL FOUND  |   |

**PARTIAL RETRACEMENT SURVEY**  
 SECTION 10, TOWN 3, RANGE 13  
 BETWEEN THE MIAMI RIVERS SURVEY  
 MIAMI TOWNSHIP  
 LOGAN COUNTY, OHIO

| DRAWN BY: | DESCRIPTION | REV. NO. | DATE      |
|-----------|-------------|----------|-----------|
| KSS       |             |          | 5/11/2021 |
|           |             |          |           |
|           |             |          |           |
|           |             |          |           |

INDEXED ON MAP  
 4126

3-6-2024



**APPROVED**



**Legal Description**  
**0.716 acres**

The following described tract of land is situated in the State of Ohio, Logan County, Miami Township, Northeast ¼ Section 10, Township 3, Range 13, MRS, being all of Kristina D. Dupuis's 0.5 acre Tract II and 0.216 acre Tract I described in Official Record 1157, page 484, and being more particularly described as follows:

Commencing at a stone found marking the intersection of the centerline of Township Road 295 with the centerline of County Road 64 (60');

Thence North 05°08'11" East 1775.00 feet, following the centerline of County Road 64 to a MAG nail found marking the southwest corner of said 0.5 acre tract and marking the **point of beginning**;

Thence **North 05°08'11" East 188.53 feet**, following the centerline of County Road 64 and the west line of said 0.5 acre tract, to a MAG nail found marking a southwest corner of Bruce E. Weeks' and Gary L. Weeks' 136.349 acre Tract III (O.R. 974, page 19, O.R. 974, page 1);

Thence **South 84°55'46" East 165.50 feet**, following the north line of said 0.5 acre and 0.216 acre tracts and the south line of said 136.349 acre tract, passing at 30.00 feet a 5/8" iron pin found, to an iron pin set;

Thence **South 05°08'32" West 188.56 feet**, following the east line of said 0.216 acre tract and the west line of said 136.349 acre tract, to a 5/8" iron pin found in the north line of William E. and Sandra E. Moore Trustees' 17.5 acre Tract I (O.R. 405, page 526);

Thence **North 84°55'07" West 165.48 feet**, following the south lines of said 0.216 acre and 0.5 acre tracts and the north line of said 17.5 acre tract, passing at 135.48 feet a 5/8" iron pin found to the **point of beginning**, containing **0.716 acres**, more or less, having 0.130 acres in the road right of way. Subject to all valid easements and restrictions of record.

I, Timothy L. Guider, hereby certify that this description was prepared from an actual field survey made by me during the month of March 2024 and that monuments were set or found as indicated herein. Iron pins set are 5/8" x 30" reinforcing rods with caps marked "GUIDER S 7752". Basis of Bearing: State Plane Coordinate System, Ohio North Zone, NAD83.

Timothy L. Guider R.S. #7752  
Guider Winkle Partners, Inc.  
19541 Delaware County Line Rd.  
Marysville, Ohio 43040  
(740)666-8902

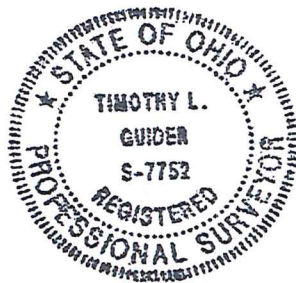

Date: 3/4/24  
Job# 24040-0.716



3-6-2024

**APPROVED**

# Plat of Survey Guider Winkle Partners, Inc.

State of Ohio, Logan County, Miami Township  
Northeast 1/4 Section 10, Township 3, Range 13, MRS

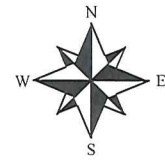
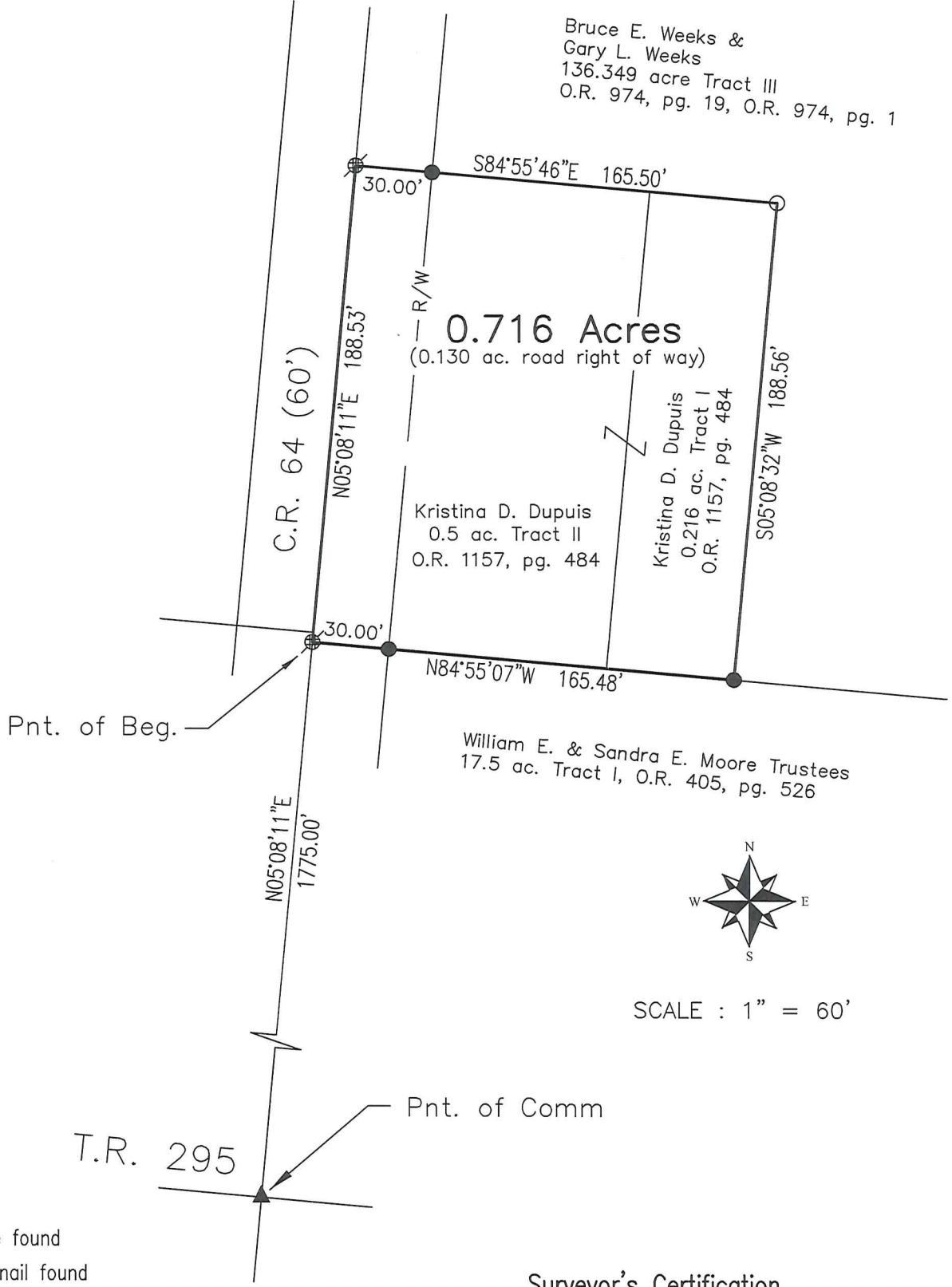

SCALE : 1" = 60'

T.R. 295

### Legend

- ▲ - Stone found
- ⊕ - MAG nail found
- - 5/8" Iron pin found
- - 5/8" x 30" Iron pin set with cap marked "GUIDER S 7752"

### Basis of Bearing

State Plane Coordinate System  
Ohio North Zone, NAD83

Scale in Feet

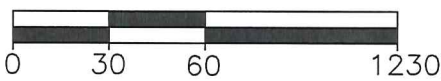

### Surveyor's Certification

I hereby certify that this plat is an accurate representation of a field survey made by me and is correct to the best of my knowledge.

*Timothy L. Guider*

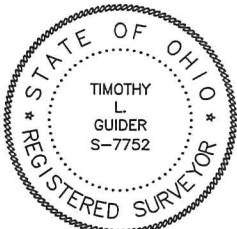

Timothy L. Guider R.S. #7752  
Guider Winkle Partners, Inc.  
19541 Delaware County Line Road  
Marysville, Ohio 43040  
(740)-666-8902

3/4/24  
Date

INDEXED ON MAP  
4126

Job#24040