

Received 10-24-90

LESLIE H. GEESLIN
REGISTERED SURVEYOR NO. 5248
P. O. BOX 274
RUSHSVLVANIA, OHIO 43347

TELEPHONE: (513) 468-2793

ELLIS SURVEY

October, 1990

The following described real estate situated in the State of Ohio, County of Logan, Township of Pleasant, being part of Section 7, Town 2, Range 14, partly in the Village of DeGraff and more particularly described as follows:

Beginning at a 5/8 inch iron bar found in the south line of Nevin Hirschfeld's 40.66 acre tract at the northwest corner of the Village of DeGraff's 22.029 acre tract as described in O. R. Vol. 105 page 219.

Thence with said Village's west line S. 00° 03' 49" E. 1353.56 feet to a 5/8 inch iron bar found at the northwest corner of said Village of DeGraff's 4.95 acre tract as described in D. B. Vol. 353 Page 973.

Thence with said Village's west line S. 00° 08' 17" W. 149.53 feet to a 5/8 inch iron bar set at the northeast corner of Hershel Smith's 0.43 acre tract as described in D. B. Vol. 377 Page 892.

Thence with said Smith's north line and the north line of Charles Shirk's 0.58 acre tract as described in O. R. Vol. 92 Page 16 S. 89° 56' 04" W. 164.29 feet to a 5/8 inch iron bar found at the southeast corner of Otilia Harrod's 0.71 acre tract as described in D. B. Vol. 375 Page 382.

Thence with said Harrod's east line, the east line of Roxella Line's 0.50 acre tract as described in O. R. Vol. 97 Page 184, the east line of Terry Campbell's 0.50 acre tract (D.B.Vol. 370 Page 130), The east line of Harold Short's 0.50 acre tract (D. B. Vol. 391 Page 473), the east line of Earl Dodds' three 0.50 acre tracts (O. R. Vol. 97 Page 180) (D. B. Vol. 338 Page 413) (D. B. Vol. 349 Page 26), the east line of Dale Evans' 0.50 acre tract (O. R. Vol. 75 Page 182) and the east line of Lowell Hill's 1.00 acre tract (O. R. Vol. 15 Page 989) N. 30° 16' 14" W. 1352.45 feet to a 5/8 inch iron bar found at the southeast corner of Virgil Osborne's 0.301 acre tract as described in O. R. Vol. 10 Page 888

INDEXED ON MAP
562 210-1

Thence with said Osborne's east line and the east line of James Notestine's 0.959 acre tract as described in O. R. Vol. 44 Page 679 N. 78° 58' 22" W. 227.40 feet to a 5/8 inch iron bar found.

Thence with said Osborne's north line S. 74° 45' 39" W. 270.70 feet to a 5/8 inch iron bar found in the centerline of County Highway 24.

Thence with said centerline N. 00° 56' 22" E. 173.45 feet to a railroad spike found at the southwest corner of Nevin Hirschfeld's 40.66 acre tract as described in O. R. Vol. 10 Page 238.

Thence with said Hirschfeld's south line N. 89° 37' 40" E. 1134.80 feet to the place of beginning.

Containing 20.968 acres more or less, of which 0.097 acre is in the right-of-way of C. H. 24 and 0.46 acre is in the Village of DeGraff.

Bearings are based in an assumed bearing for the west line of the Village's 22.029 acre tract in this field survey.



INDEXED ON MAP
56221D-2

Leslie H. Geeslin

N. 89° 37' 40" E. 1134.80'

N. 00° 56' 22" E. 178.43'
S. 74° 45' 39" W. 270.70'
JAMES NDETESTINE
0.959 AC
D.R. VOL. 44 PG 679

VIRGIL OSBORNE
0.301 AC
D.R. VOL 10 PAGE 288

LOWELL HILL
1.00 AC.
D.R. VOL 15
PAGE 989

DALE EVANS
0.50 AC.
D.R. VOL. 75
PAGE 182

EARL DODDS
0.50 AC
D.B. VOL. 349
PAGE 26

EARL DODDS
0.50 AC.
D.B. VOL. 338
PAGE. 413

EARL DODDS
0.50 AC.
D.R. VOL. 97
PAGE 180

HAROLD SHORT
0.50 AC.
D.B. VOL. 391
PAGE 473

TERRY CAMPBELL
0.50 AC.
D.B. VOL. 370
PAGE 130

ROXELLA LINE
0.50 AC.
D.R. VOL 97
PAGE 184

OTILIA HARROD
0.71 AC.
D.B. VOL. 375
PAGE 382

CHARLES SHIRK
0.58 AC
D.R. VOL. 92
PAGE 16

HERSHEL SMITH
0.43 AC
D.B. VOL. 377
PAGE 872

20.968 AC

VILLAGE OF DEGRAFF
22.029 AC
D.R. VOL. 105 PAGE 219

VILLAGE OF DEGRAFF
4.95 AC.
D.B. VOL 353 PAGE 973

- LEGEND
- = R.R. SPIKE FOUND
 - = 5/8" IRON BAR FOUND
 - = 5/8" IRON BAR SET

SURVEY OF 20.968 AC TRACT IN
SECTION 7, TOWN 2, RANGE 14 'N
PLEASANT TOWNSHIP, LOGAN COUNTY,
OHIO BY JAMES ELLIS
OCTOBER 23, 1990
SCALE: 1" = 100'

C O R P O R A T I O N L I N E

N. 00° 39' 38" E. 405.63'

923.28'

N. 00° 18' 50" W.



Leslie H. Geeslin
LESLIE H. GEESLIN
RUSHSVLVANIA, OHIO
(513) 468-2793

INDEXED ON MAP
54221P

SURVEY FOR JAMES H. ELLIS
PLEASANT TOWNSHIP
JANUARY 6, 1990

The following described tract is located in the State of Ohio, County of Logan, Township of Pleasant and is part of Section 7, Town 2, Range 14 of the Between the Miami Rivers Survey. Said tract is also part of James H. Ellis' 46.02 acre Tract II as described in Deed Book Volume 306, Page 295 and is more fully described as follows:

Commencing at a 3/4 inch diameter iron bar found in the center of Pleasant Street in the Village of De Graff as shown in Field Book No. 707, Page 33, said iron bar being the southeast corner of the Village of De Graff's 4.95 acre tract as described in Deed Book Volume 353, Page 973;

Thence with the east line of the Village of De Graff's tract North-0°-18'-50"-West 325.00 feet to a 5/8 inch diameter iron bar set at the northeast corner of the Village of De Graff's tract, said iron bar being the place of beginning of this description,

Thence with the north line of the Village of De Graff's tract South-88°-01'-12"-West 716.12 feet to a 3/4 inch diameter iron bar found at the northwest corner of the Village of De Graff's tract,

Thence North-0°-04'-30"-West 1353.78 feet to a 5/8 inch diameter iron bar set in the south line of Nevin F. Hirschfeld's 40.66 acre tract as described in Official Records Volume 10, Page 238,

Thence with the south line of Hirschfeld's tract North-89°-35'-39"-East 717.10 feet to a concrete end post found at the northwest corner of Greenwood Cemetery as described in Deed Book Volume 123, Page 385,

Thence with the west line of Greenwood Cemetery South-0°-39'-49"-West 405.81 feet to a 5/8 inch diameter iron bar set,

Thence continuing with the west line of Greenwood Cemetery South-0°-18'-50"-East 928.34 feet to the place of beginning.

The above described tract contains 22.029 acres taken from Permanent Parcel No. 34-102-00-00-044, and the description is based upon a field survey performed on January 6, 1990.

Leslie H. Geeslin
LESLIE H. GEESLIN
REG. NO. 5248
RUSHSVLVANIA OHIO

INDEXED ON MAP
5622-2D

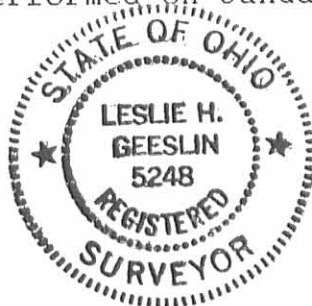

Bearings are based on an assumed bearing for the north line of the Village of DeGraff's 4.95 acre tract in this field survey.

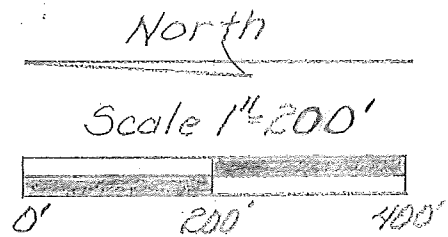

Legend:
 A = Conc. End Post Fd.
 B = 5/8" ϕ Iron bar Set
 C = 3/4" ϕ Iron bar Fd.

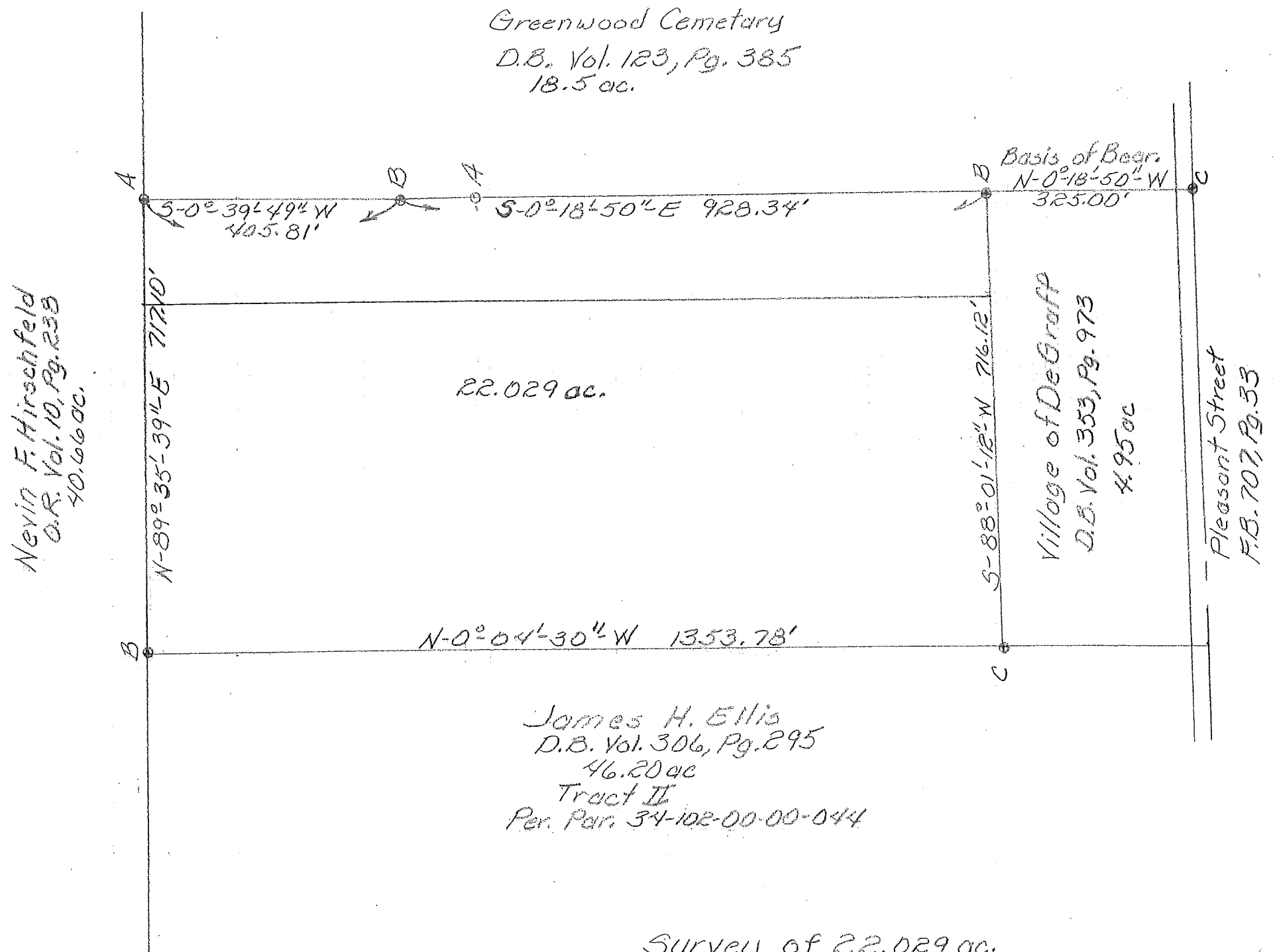

INDEXED ON MAP
 5622

Survey of 22.029 ac.
 for James H. Ellis
 Sec. 7, Town 2, Range 14
 B.M.R.S. Pleasant Twp.
 Logan County, Ohio
 January 6, 1990

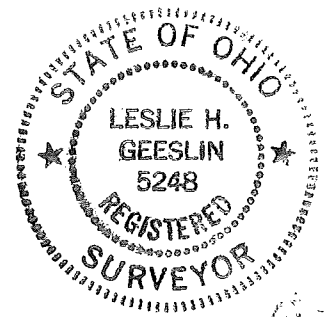

Leslie H. Geeslin
 Leslie H. Geeslin
 Reg. No. 5248
 Rushsylvania, Ohio

By JKC

REC'D 4-26-10 SMY ak

Lee Surveying and Mapping Co., Inc.

Land Surveys • Topography • Subdivisions • Construction Layout

117 N. Madriver St.
Bellefontaine OH 43311



Phone: (937) 593-7335
Fax: (937) 593-7444
surveys@lsminc.us

VILLAGE OF DEGRAFF 4.400 ACRES

Lying in Section 7, Town 2, Range 14, Village of DeGraff, Pleasant Township, Logan County, Ohio.

Being out of the Village of DeGraff original 22.029 acre tract as deeded and described in Official Record 105, Page 219 of the Logan County Records of Deeds and being more particularly described as follows:

Commencing on a 2 inch iron pipe found on the intersection of the south line of Pleasant Township and the center-line of County Highway 24 at Station 0+00 (Logan County Engineer's Field Book 516, Page 63).

THENCE, with the south line of Pleasant Township, S 85°-21'-35"E, a distance of 245.54 feet to a point.

THENCE, with the east line extended and the east line of the Herschel A. Smith and Josefina A. Smith, Trustees, 0.43 acre tract (O.R. 938, Pg. 323) and the east line of the David A. Reames and Dixie D. Reames 20.968 acre tract (O.R. 116, Pg. 610), N 04°-41'-23"E, a distance of 356.78 feet to a 3/4 inch iron rod found on a west line of the DeGraff Corporation Line, passing a 3/4 inch iron rod found on the center-line of Pleasant Street (50 feet wide) at 31.90 feet and a 5/8 inch iron rod found at 207.39 feet.

THENCE, with a west line of the DeGraff Corporation Line and the east line of the said 20.968 acre tract, N 04°-27'-05"E, a distance of 967.65 feet to a 5/8 inch iron rod set at the TRUE POINT OF BEGINNING, passing a 5/8 inch iron rod set at 426.60 feet.

THENCE, with a west line of the DeGraff Corporation Line and the east line of the said 20.968 acre tract, N 04°-27'-05"E, a distance of 385.98 feet to a 5/8 inch iron rod found.

THENCE, with a north line of the DeGraff Corporation Line and the south lines of The DeGraff United Methodist Church of DeGraff, Ohio 11.098 acre tract (O.R. 612, Pg. 133) and the Dale N. Hirschfeld, Trustee, 29.562 acre tract (O.R. 902, Pg. 617, Tract I), S 85°-52'-17"E, a distance of 495.56 feet to a 5/8 inch iron rod found.

THENCE, with the west line of The Trustees of the Greenwood-Union Cemetery Board and The Village of DeGraff, Ohio, 5.000 acre tract (O.R. 369, Pg. 271), S 04°-07'-33"W, a distance of 385.85 feet to a 5/8 inch iron rod set.

THENCE, N 85°-53'-08"W, a distance of 497.75 feet to the point of beginning.

Containing 4.400 acres.

This parcel is to be attached to an adjoining tract of land and is not to be used as a separate and independent parcel.

Property is subject to any and all previous easements and rights-of-way of record.

The basis for bearings is the south line of Pleasant Township, being S 85°-21'-35"E, and all other bearings are from angles and distances measured in a field survey by Lee Surveying and Mapping Co., Inc. on April 15, 2010.

Description prepared by:

A handwritten signature in black ink that reads "William K. Bruce".

William K. Bruce
Professional Surveyor 7437
April 21, 2010



4938410

Lee Surveying and Mapping Co., Inc.

Land Surveys • Topography • Subdivisions • Construction Layout

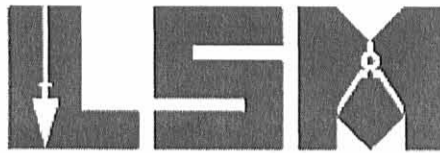
117 N. Madriver St.
Bellefontaine OH 43311Phone: (937) 593-7335
Fax: (937) 593-7444
surveys@lsminc.us

REAMES 4.400 ACRES

Lying in Section 7, Town 2, Range 14, Village of DeGraff, Pleasant Township, Logan County, Ohio.

Being out of the David A. Reames and Dixie D. Reames 20.968 acre tract as deeded and described in Official Record 116, Page 610 of the Logan County Records of Deeds and being more particularly described as follows:

Commencing on a 2 inch iron pipe found on the intersection of the south line of Pleasant Township and the center-line of County Highway 24 at Station 0+00 (Logan County Engineer's Field Book 516, Page 63).

THENCE, with the south line of Pleasant Township, S 85°-21'-35"E, a distance of 245.54 feet to a point.

THENCE, with the east line extended and the east line of the Herschel A. Smith and Josefina A. Smith, Trustees, 0.43 acre tract (O.R. 938, Pg. 323), N 04°-41'-23"E, a distance of 207.39 feet to a 5/8 inch iron rod found at the TRUE POINT OF BEGINNING, passing a 3/4 inch iron rod found on the center-line of Pleasant Street (50 feet wide) at 31.90 feet.

THENCE, with the north lines of the said 0.43 acre tract and the Carl E. Rucker 0.58 acre tract (O.R. 515, Pg. 667), N 85°-26'-46"W, a distance of 164.22 feet to a 3/4 inch iron rod found.

THENCE, with the easterly lines of the Otilia Harrod 0.71 acre tract (Vol. 375, Pg. 382), the Carlos E. Recinos 0.50 acre tract (O.R. 366, Pg. 199), the Jason L. Purtee 0.50 acre tract (O.R. 897, Pg. 699), the Franklin M. Wilkinson, Jr. 0.50 acre tract (O.R. 265, Pg. 490) and the Earl I. Dodds 0.50 acre tract (O.R. 97, Pg. 180), N 25°-43'-12"W, a distance of 668.04 feet to a 5/8 inch iron rod set.

THENCE, S 85°-20'-15"E, a distance of 500.58 feet to a 5/8 inch iron rod set on a west line of the DeGraff Corporation Line.

THENCE, with the west line of the DeGraff Corporation Line and the west line of the Village of DeGraff original 22.029 acre tract (O.R. 105, Pg. 219), S 04°-27'-05"W, a distance of 426.60 feet to a 3/4 inch iron rod found.

THENCE, with the west line of the DeGraff Corporation Line and said line extended and the west line of The Village of DeGraff, Ohio 4.95 acre tract (Vol. 353, Pg. 973), S 04°-41'-23"W, a distance of 149.39 feet to the point of beginning.

Containing 4.400 acres.

This parcel is to be attached to an adjoining tract of land and is not to be used as a separate and independent parcel.

Property is subject to any and all previous easements and rights-of-way of record.

The basis for bearings is the south line of Pleasant Township, being S 85°-21'-35"E, and all other bearings are from angles and distances measured in a field survey by Lee Surveying and Mapping Co., Inc. on April 15, 2010.



ORIGINAL STAMP IN GREEN

Description prepared by:

A handwritten signature in cursive that reads 'William K. Bruce'.

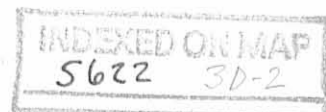
William K. Bruce
Professional Surveyor 7437
April 21, 2010

4938410

REV'D 4-26-10 SMM/BLW

LEGEND:

- 5/8 INCH IRON ROD FOUND
- 5/8 INCH IRON ROD SET WITH PLASTIC I.D. CAP STAMPED "LSM 7437"
- ◎ 3/4 INCH IRON ROD FOUND
- ⊕ 2 INCH IRON PIPE FOUND

THE DEGRAFF UNITED METHODIST CHURCH OF DEGRAFF, OHIO
11.098 ACRES
O.R. 612, PG. 133

DALE N. HIRSCHFELD, TRUSTEE
29.562 ACRES
O.R. 902, PG. 617
TRACT 1

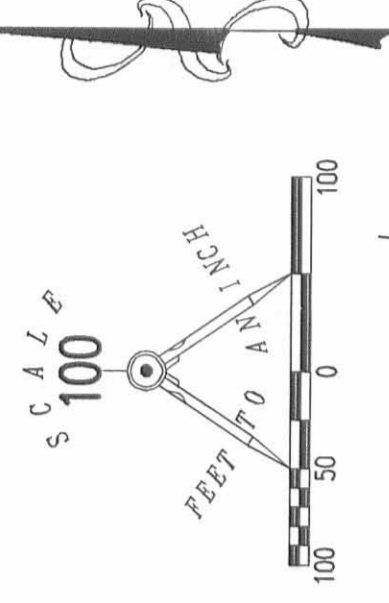

DEGRAFF CORPORATION LINE
S 85°52'17" E 495.56'

4.400 ACRES

S 04°07'33" W 385.85'

N 85°53'08" W 497.75'

THE TRUSTEES OF THE GREENWOOD-UNION CEMETERY BOARD AND THE VILLAGE OF DEGRAFF, OHIO
5.000 ACRES
O.R. 369, PG. 271

S 04°07'33" W 622.78'

VILLAGE OF DEGRAFF
ORIGINAL 22.029 ACRES
O.R. 105, PG. 219

N 04°27'05" E 385.98'

N 04°27'05" E 541.05'

DAVID A. REAMES AND DIXIE D. REAMES
20.968 ACRES
O.R. 116, PG. 610

S 85°20'15" E 500.58'

4.400 ACRES

S 04°41'23" W 426.60'

N 25°43'12" W 309.35'

E 04°00'00" S 0.50 ACRE
O.R. 91, PG. 180

FRANKLIN M. WILKINSON, JR.
O.R. 265, PG. 490

JASON L. PURTEE
O.R. 891, PG. 899

CARLOS E. REYNOLDS
O.R. 366, PG. 199

N 25°43'12" W 668.04'

DEGRAFF CORPORATION LINE
(3.824 ACRES)
(0.576 ACRE)

OTILIA HARROD
0.71 ACRE
VOL. 375, PG. 362

CARL E. RUCKER
0.58 ACRE
O.R. 515, PG. 667

HERSCHEL A. SMITH AND JOSEFINA A. SMITH
0.43 ACRE
O.R. 938, PG. 323

N 85°26'46" W 164.22'

S 04°41'23" W 149.39'

THE VILLAGE OF DEGRAFF, OHIO
4.95 ACRES
VOL. 353, PG. 973

PLEASANT STREET (50')

PLEASANT TOWNSHIP
MIAMI TOWNSHIP

STATION 0+00
(LOGAN COUNTY ENGINEER'S FIELD BOOK 516, PAGE 63)

NOTE:
THESE PARCELS ARE TO BE ATTACHED TO ADJOINING TRACTS OF LAND AND ARE NOT TO BE USED AS SEPARATE AND INDEPENDENT PARCELS.

2 WORKING DAYS

BEFORE YOU DIG
CALL TOLL FREE 800-362-2764
OHIO UTILITIES PROTECTION SERVICE.

INDEXED ON MAP
5622 3P

SURVEY OF 4.400 ACRES OUT OF THE VILLAGE OF DEGRAFF ORIGINAL 22.029 ACRE TRACT OFFICIAL RECORD 105, PAGE 219

A N D

SURVEY OF 4.400 ACRES OUT OF THE DAVID A. REAMES AND DIXIE D. REAMES 20.968 ACRES

OFFICIAL RECORD 116, PAGE 610 SECTION 7, TOWN 2, RANGE 14 VILLAGE OF DEGRAFF PLEASANT TOWNSHIP LOGAN COUNTY, OHIO

SURVEYED BY:

WILLIAM K. BRUCE
PROFESSIONAL SURVEYOR 7437
APRIL 15, 2010



COPYRIGHT 2010 BY:
LEE SURVEYING & MAPPING CO., INC.
117 North Main Street, S.F. 601,
BELLEFONTAINE, OHIO 43311
(937) 593-7335
surveys@lsminc.us

KSS D0410 4938410 L-4938-2

Lee Surveying and Mapping Co., Inc.

Land Surveys • Topography • Subdivisions • Construction Layout

117 N. Madriver St.
Bellefontaine OH 43311



Phone: (937) 593-7335
Fax: (937) 593-7444
surveys@lsminc.us

VILLAGE OF DEGRAFF 4.515 ACRES

Lying in Section 7, Town 2, Range 14, Village of DeGraff, Pleasant Township, Logan County, Ohio.

Being out of the Village of DeGraff original 22.029 acre tract as deeded and described in Official Record 105, Page 219 of the Logan County Records of Deeds and being more particularly described as follows:

Commencing on a 2 inch iron pipe found on the intersection of the south line of Pleasant Township and the center-line of County Highway 24 at Station 0+00 (Logan County Engineer's Field Book 516, Page 63).

THENCE, with the south line of Pleasant Township, S 85°-21'-35"E, a distance of 245.54 feet to a point.

THENCE, with the east line extended and the east line of the Herschel A. Smith and Josefina A. Smith, Trustees, 0.43 acre tract (O.R. 938, Pg. 323) and the east line of The Village of DeGraff 4.400 acre tract (O.R. 991, Pg. 903), N 04°-41'-23"E, a distance of 356.78 feet to a 3/4 inch iron rod found on a west line of the DeGraff Corporation Line, passing a 3/4 inch iron rod found on the center-line of Pleasant Street (50 feet wide) at 31.90 feet and a 5/8 inch iron rod found at 207.39 feet.

THENCE, with a west line of the DeGraff Corporation Line and the east line of the said 4.400 acre tract, N 04°-27'-05"E, a distance of 426.60 feet to a 5/8 inch iron rod found.

THENCE, with a west line of the DeGraff Corporation Line and an east line of the David A. Reames and Dixie D. Reames original 20.968 acre tract (O.R. 116, Pg. 610), N 04°-27'-05"E, a distance of 148.25 feet to a 5/8 inch iron rod set at the TRUE POINT OF BEGINNING.

THENCE, with a west line of the DeGraff Corporation Line and the east line of the said 20.968 acre tract, N 04°-27'-05"E, a distance of 392.80 feet to a 5/8 inch iron rod found.

THENCE, with the south line of the David A. Reames and Dixie D. Reames 4.400 acre tract (O.R. 991, Pg. 532), S 85°-53'-08"E, a distance of 497.75 feet to a 5/8 inch iron rod found.

THENCE, with the west line of The Trustees of the Greenwood-Union Cemetery Board and The Village of DeGraff, Ohio, 5.000 acre tract (O.R. 369, Pg. 271), S 04°-07'-33"W, a distance of 395.76 feet to a 5/8 inch iron rod set.

Lee Surveying and Mapping Co., Inc.

Land Surveys • Topography • Subdivisions • Construction Layout

117 N. Madriver St.
Bellefontaine OH 43311



Phone: (937) 593-7335
Fax: (937) 593-7444
surveys@lsminc.us

THENCE, N 85°-32'-44"W, a distance of 499.99 feet to the point of beginning.

Containing 4.515 acres.

This parcel is to be attached to an adjoining tract of land and is not to be used as a separate and independent parcel.

Property is subject to any and all previous easements and rights-of-way of record.

The basis for bearings is the south line of Pleasant Township, being S 85°-21'-35"E, and all other bearings are from angles and distances measured in a field survey by Lee Surveying and Mapping Co., Inc. on August 4, 2010.

Description prepared by:

A handwritten signature in black ink that reads "William K. Bruce".

William K. Bruce
Professional Surveyor 7437
August 4, 2010



ORIGINAL STAMP IN GREEN

4938710

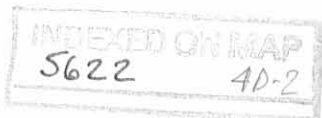

LEGEND:

- 5/8 INCH IRON ROD FOUND
- 5/8 INCH IRON ROD SET WITH PLASTIC I.D. CAP STAMPED "LSM 7437"
- ⊙ 3/4 INCH IRON ROD FOUND
- ⊕ 2 INCH IRON PIPE FOUND

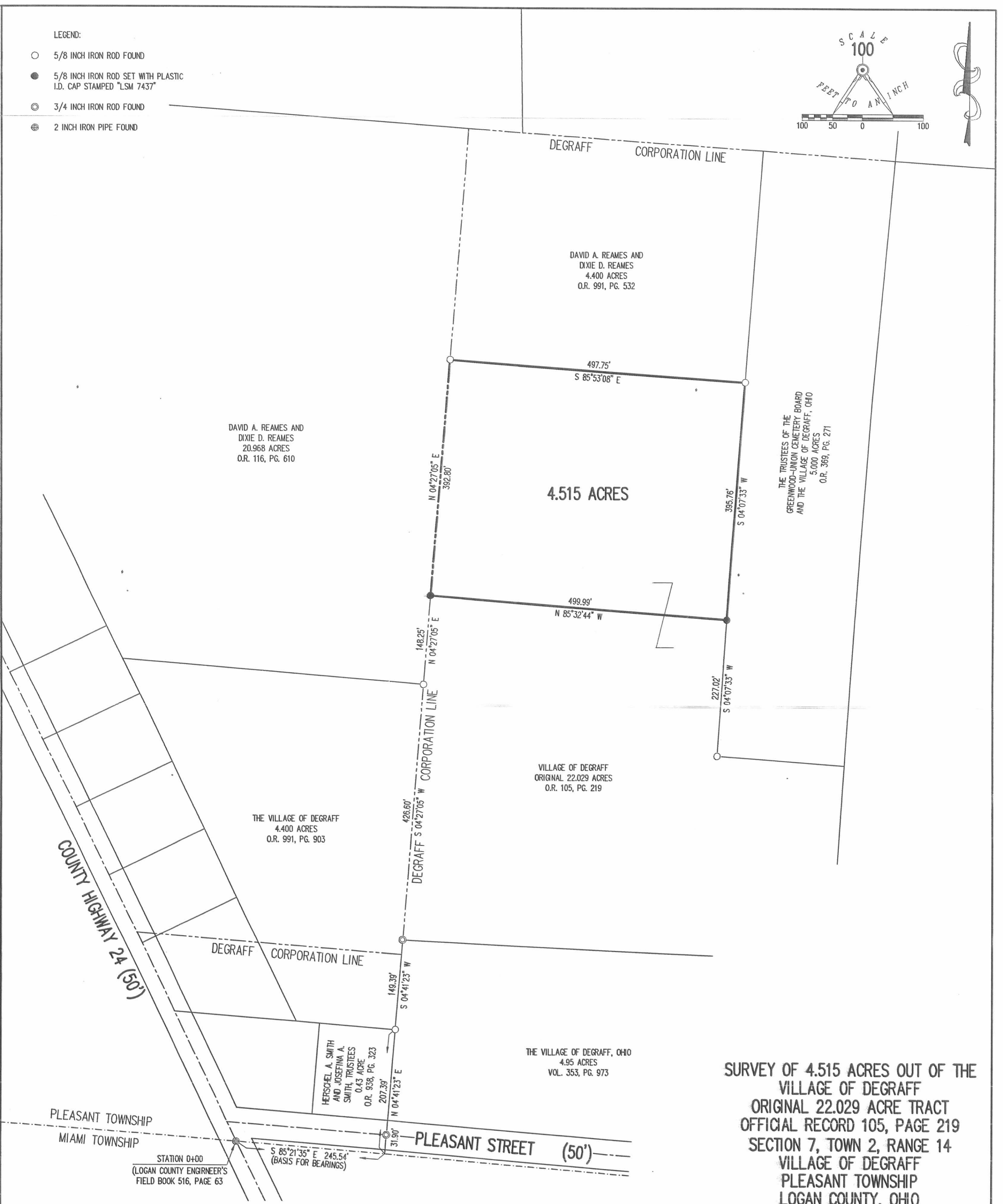
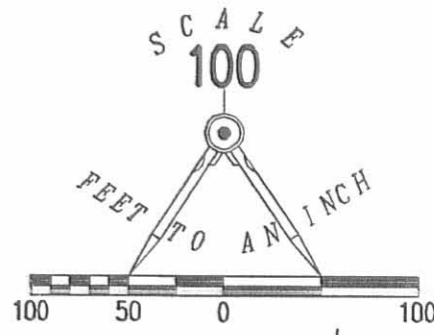

SURVEY OF 4.515 ACRES OUT OF THE VILLAGE OF DEGRAFF ORIGINAL 22.029 ACRE TRACT OFFICIAL RECORD 105, PAGE 219 SECTION 7, TOWN 2, RANGE 14 VILLAGE OF DEGRAFF PLEASANT TOWNSHIP LOGAN COUNTY, OHIO

SURVEYED BY:

William K. Bruce
WILLIAM K. BRUCE
PROFESSIONAL SURVEYOR 7437
AUGUST 4, 2010

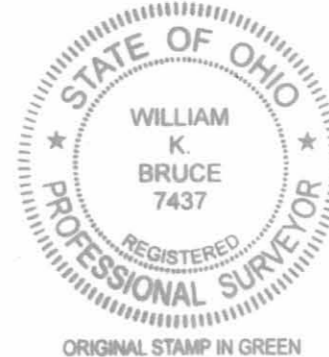

COPYRIGHT 2010 BY:
LEE SURVEYING & MAPPING CO., INC.
117 North Modriver Street
BELLEFONTAINE, OHIO 43311
(937) 593-7335
surveys@lsminc.us

KSS D0710 4938710 L-4938-2

NOTE:

THIS PARCEL IS TO BE ATTACHED TO AN ADJOINING TRACT OF LAND AND IS NOT TO BE USED AS SEPARATE AND INDEPENDENT PARCEL.

2 WORKING DAYS
BEFORE YOU DIG

CALL TOLL FREE **800-362-2764**
OHIO UTILITIES PROTECTION SERVICE.

INDEXED ON MAP
5622 4P