

1 REID 10-16-06 SMYOK

Lee Surveying and Mapping Co., Inc.

Land Surveys • Topography • Subdivisions • Construction Layout

117 N. Madriver St.
Bellefontaine OH 43311



Phone: (937) 593-7335
Fax: (937) 593-7444

1975-2005 - 30 YEARS OF EXCELLENCE

**WILSON
1.563 ACRES**

Lying in Section 9, Town 1, Range 8, Pleasant Township, Logan County, Ohio.

Being out of the Chuck Wilson and Stephanie Jones 13.529 acre tract as deeded and described in Official Record 468, Page 598 of the Logan County Records of Deeds and being more particularly described as follows:

Commencing on a PK nail found on the west line of Section 9 at the intersection of center-lines of Ohio Route 47 and County Highway 23.

THENCE, with the west line of Section 9 and the center-line of County Highway 23 (60 feet wide), N 1°-04'-30"E, a distance of 913.64 feet to a railroad spike found at the TRUE POINT OF BEGINNING.

THENCE, with the west line of Section 9 and the center-line of County Highway 23, N 1°-04'-30"E, a distance of 100.27 feet to a railroad spike found on the north line of the southwest quarter of Section 9.

THENCE, with the north line of the southwest quarter of Section 9 and the south line of the William F. Pence original 35 acre tract (O.R. 440, Pg. 258), S 89°-23'-36"E, a distance of 507.16 feet to a 5/8 inch iron rod set, passing a 5/8 inch iron rod found at 30.05 feet.

THENCE, S 2°-19'-53"W, a distance of 162.93 feet to a 5/8 inch iron rod set.

THENCE, S 88°-58'-18"W, a distance of 279.13 feet to a 5/8 inch iron rod set.

THENCE, with the lines of the Steven J. Schweitzer 2.308 acre tract (O.R. 116, pg. 194), the following two courses:

N 1°-04'-30"E, a distance of 81.73 feet to a 1/2 inch iron rod found.

S 87°-45'-40"W, a distance of 225.00 feet to the point of beginning, passing a 1/2 inch iron rod found at 194.95 feet.

Containing 1.563 acres, of which 0.069 acre is within the highway right-of-way.

The basis for bearings is the west line of Section 9, being N 1°-04'-30"E, and all other bearings are from angles and distances measured in a field survey by Lee Surveying and Mapping Co., Inc. on October 12, 2006.



ORIGINAL STAMP IN GREEN

Description prepared by:

A handwritten signature in black ink, appearing to be 'J. Lee', written over the typed name and title.
Jeffrey I. Lee
Professional Surveyor 6359
October 12, 2006

1480096

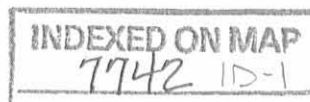

REC'D 10-16-06 SML & L

Lee Surveying and Mapping Co., Inc.

Land Surveys • Topography • Subdivisions • Construction Layout

117 N. Madriver St.
Bellefontaine OH 43311

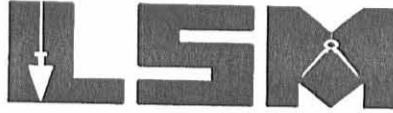

Phone: (937) 593-7335
Fax: (937) 593-7444

1975-2005 - 30 YEARS OF EXCELLENCE

**WILSON
11.965 ACRES**

Lying in Section 9, Town 1, Range 8, Pleasant Township, Logan County, Ohio.

Being out of the Chuck Wilson and Stephanie Jones 13.529 acre tract as deeded and described in Official Record 468, Page 598 of the Logan County Records of Deeds and being more particularly described as follows:

Commencing on a PK nail found on the west line of Section 9 at the intersection of center-lines of Ohio Route 47 and County Highway 23.

THENCE, with the west line of Section 9 and the center-line of County Highway 23 (60 feet wide), N 1°-04'-30"E, a distance of 1013.91 feet to a railroad spike found on the north line of the southwest quarter of Section 9.

THENCE, with the north line of the southwest quarter of Section 9 and the south line of the William F. Pence original 35 acre tract (O.R. 440, Pg. 258), S 89°-23'-36"E, a distance of 507.16 feet to a 5/8 inch iron rod set at the TRUE POINT OF BEGINNING, passing a 5/8 inch iron rod found at 30.05 feet.

THENCE, with the north line of the southwest quarter of Section 9 and the south line of the said 35 acre tract, S 89°-23'-36"E, a distance of 686.16 feet to a 5/8 inch iron rod found.

THENCE, with the westerly line of the D.T. & I. Railroad, S 30°-43'-55"E, a distance of 554.97 feet to a 1/2 inch iron rod found.

THENCE, with the north lines of the Sherry L. Vonderhuevel 2.168 acre tract and 2.136 acre tract (O.R. 332, Pg. 225, Parcel II and Parcel I), the Dennis M. Keith 2.136 acre tract (O.R. 412, Pg. 808), the Dennis M. Keith 2.136 acre tract (O.R. 412, Pg. 806), the Troy D. Shough 2.136 acre tract (O.R. 281, Pg. 311) and the Dennis Keith 2.136 acre tract and 1.082 acre tract (O.R. 315, Pg. 167, Tract II and Tract I), S 87°-45'-40"W, a distance of 1263.27 feet to a 1/2 inch iron rod found.

THENCE, with the east line of the Steven J. Schweitzer 2.308 acre tract (O.R. 116, pg. 194), N 1°-04'-30"E, a distance of 365.91 feet to a 5/8 inch iron rod set.

THENCE, N 88°-58'-18"E, a distance of 279.13 feet to a 5/8 inch iron rod set.

THENCE, N 2°-19'-53"E, a distance of 162.93 feet to the point of beginning.

Containing 11.965 acres.

The basis for bearings is the west line of Section 9, being N 1°-04'-30"E, and all other bearings are from angles and distances measured in a field survey by Lee Surveying and Mapping Co., Inc. on October 12, 2006.



ORIGINAL STAMP IN GREEN

Description prepared by:

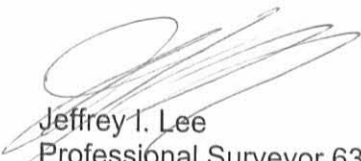
Jeffrey I. Lee
Professional Surveyor 6359
October 12, 2006

1480096

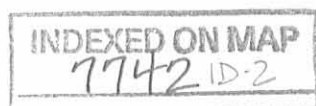

REC'D 10-16-06 SMJ OK

WILLIAM F. PENCE
ORIGINAL 35 ACRES
O.R. 440, PG. 258

1.563 ACRES
OF WHICH 0.069 ACRE IS WITHIN
THE HIGHWAY RIGHT-OF-WAY

11.965 ACRES

CHUCK WILSON AND
STEPHANIE JONES
13.529 ACRES
O.R. 468, PG. 598

COUNTY HIGHWAY 23 (60')

(BASIS FOR BEARINGS)

SECTION 8
SECTION 9

N 01°04'30" E

N 01°04'30" E

JASON M. STEWART
2.403 ACRES
O.R. 302, PG. 671

STEVEN J. SCHWEITZER
2.308 ACRES
O.R. 116, PG. 194

DENNIS M. KEITH
1.082 ACRES
O.R. 315, PG. 167
TRACT I

DENNIS KEITH
2.136 ACRES
O.R. 315, PG. 167
TRACT II

TROY D. SHOUGH
2.136 ACRES
O.R. 281, PG. 311

DENNIS M. KEITH
2.136 ACRES
O.R. 412, PG. 806

DENNIS M. KEITH
2.136 ACRES
O.R. 412, PG. 808

SHERRY L. VONDERHUEVEL
2.136 ACRES
O.R. 332, PG. 225
PARCEL I

SHERRY L. VONDERHUEVEL
2.168 ACRES
O.R. 332, PG. 225
PARCEL II

S 87°45'40" W
30.05'

S 88°58'18" W
279.13'

N 01°04'30" E
365.91'

S 89°23'36" E
507.16'

S 89°23'36" E
686.16'

S 87°45'40" W
1263.27'

S 30°43'55" E
554.97'

QUARTER SECTION LINE

D. T. & I. RAILROAD

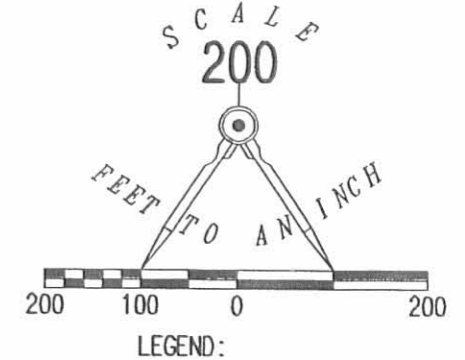

- LEGEND:
- ⊗ RAILROAD SPIKE FOUND
 - ⊘ PK NAIL FOUND
 - ⊙ 1/2 INCH IRON ROD FOUND
 - 5/8 INCH IRON ROD FOUND
 - 5/8 INCH IRON ROD SET

SURVEY OF TWO TRACTS OUT OF THE
CHUCK WILSON AND
STEPHANIE JONES
13.529 ACRE TRACT
OFFICIAL RECORD 468, PAGE 598
SECTION 9, TOWN 1, RANGE 8
PLEASANT TOWNSHIP
LOGAN COUNTY, OHIO

SURVEYED BY:

Jeffrey I. Lee
JEFFREY I. LEE
PROFESSIONAL SURVEYOR 6359
OCTOBER 12, 2006



ORIGINAL STAMP IN GREEN

COPYRIGHT 2006 BY:
LEE SURVEYING & MAPPING CO., INC.
117 North Madriver Street
BELLEFONTAINE, OHIO 43311
(937) 593-7335
KSR D1006 1480096 L-1480-3

2 WORKING DAYS
BEFORE YOU DIG
CALL TOLL FREE 800-362-2764
OHIO UTILITIES PROTECTION SERVICE.

INDEXED ON MAP
7742 IP

REC'D 3-15-96 SWY OK ✓



Lee Surveying and Mapping Co., Inc.



Farm Surveys • Lot Surveys • Topography • Subdivisions • Construction Layout

143 EAST COLUMBUS AVENUE
BELLEFONTAINE, OHIO 43311

(513) 593-7335
FAX (513) 593-7444

WILLIS PULFER 13.529 ACRES

Lying in Section 9, Town 1, Range 8, Pleasant Township, Logan County, Ohio.

Being out of the Willis Pulfer original 33.0 acre tract as deeded and described in Volume 212, Page 519 of the Logan County Records of Deeds and being more particularly described as follows:

Beginning at a railroad spike set on the northwest corner of the southwest quarter of Section 9 and on the center-line of County Highway 23.

THENCE, with the north line of the said southwest quarter and the south line of the Thomas W. Pulfer 35.0 acre tract (Vol. 382, Pg. 378), S 89°-23'-36" E, a distance of 1193.32 feet to a 5/8 inch iron rod set.

THENCE, with the westerly line of the D.T. & I. Railroad property, S 30°-43'-55" E, a distance of 554.97 feet to a 1/2 inch iron rod found.

THENCE, with the north lines of the Nancy M. Greenman 2.136 acre tract (O.R. 262, Pg. 349, Par. II), the Nancy M. Greenman 2.136 acre tract (O.R. 262, Pg. 349, Par. I), the Mark J. Blankemeyer 2.136 acre tract (O.R. 190, Pg. 271), and the said north lines extended both east and west, S 87°-45'-40" W, a distance of 1263.27 feet to a 1/2 inch iron rod found.

THENCE, with the east line of the Steven J. Schweitzer 2.308 acre tract (O.R. 116, Pg. 194) the following two courses:

N 1°-04'-30" E, a distance of 447.64 feet to a 1/2 inch iron rod found.

S 87°-45'-40" W, a distance of 225.00 feet to a railroad spike found.

THENCE, with the west line of Section 9 and the center-line of County Highway 23 (60 feet wide), N 1°-04'-30" E, a distance of 100.27 feet to the point of beginning.

Containing 13.529 acres of which 0.069 acre is within the highway rights-of-way.

The basis for bearings is the center-line of Ohio Route 47 being S 87°-45'-40" W, and all other bearings are from angles and distances measured in a field survey by Lee Surveying and Mapping Co., Inc. on January 11, 1996.

Description prepared by:

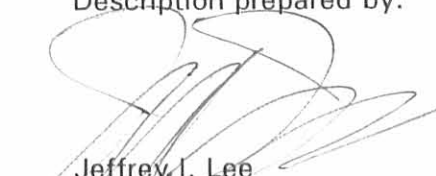
Jeffrey I. Lee
Professional Surveyor 6359
January 23, 1996.
Revised March 15, 1996

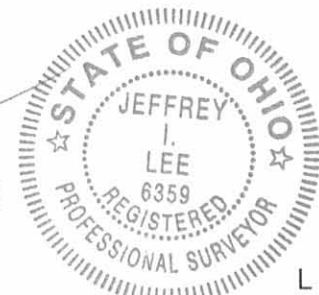

L 1480

ORIGINAL STAMP IN GREEN

INDEXED ON MAP
7742 2D

REFERENCES:

LOGAN COUNTY ENGINEER'S FILES:
R-1795, R-4411, R-341
X-23C
FIELD BOOK 208, PG. 13 & 14
FIELD BOOK 552, PG. 65-69

THOMAS W. PULFER
35.0 ACRES
VOL. 382, PG. 378

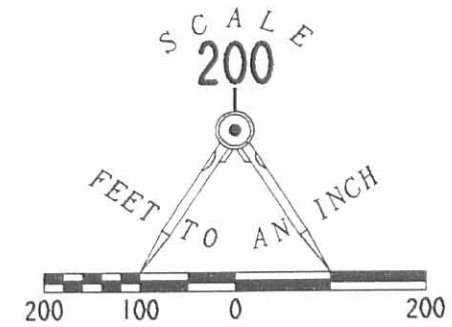

COUNTY HIGHWAY 23
60' R/W

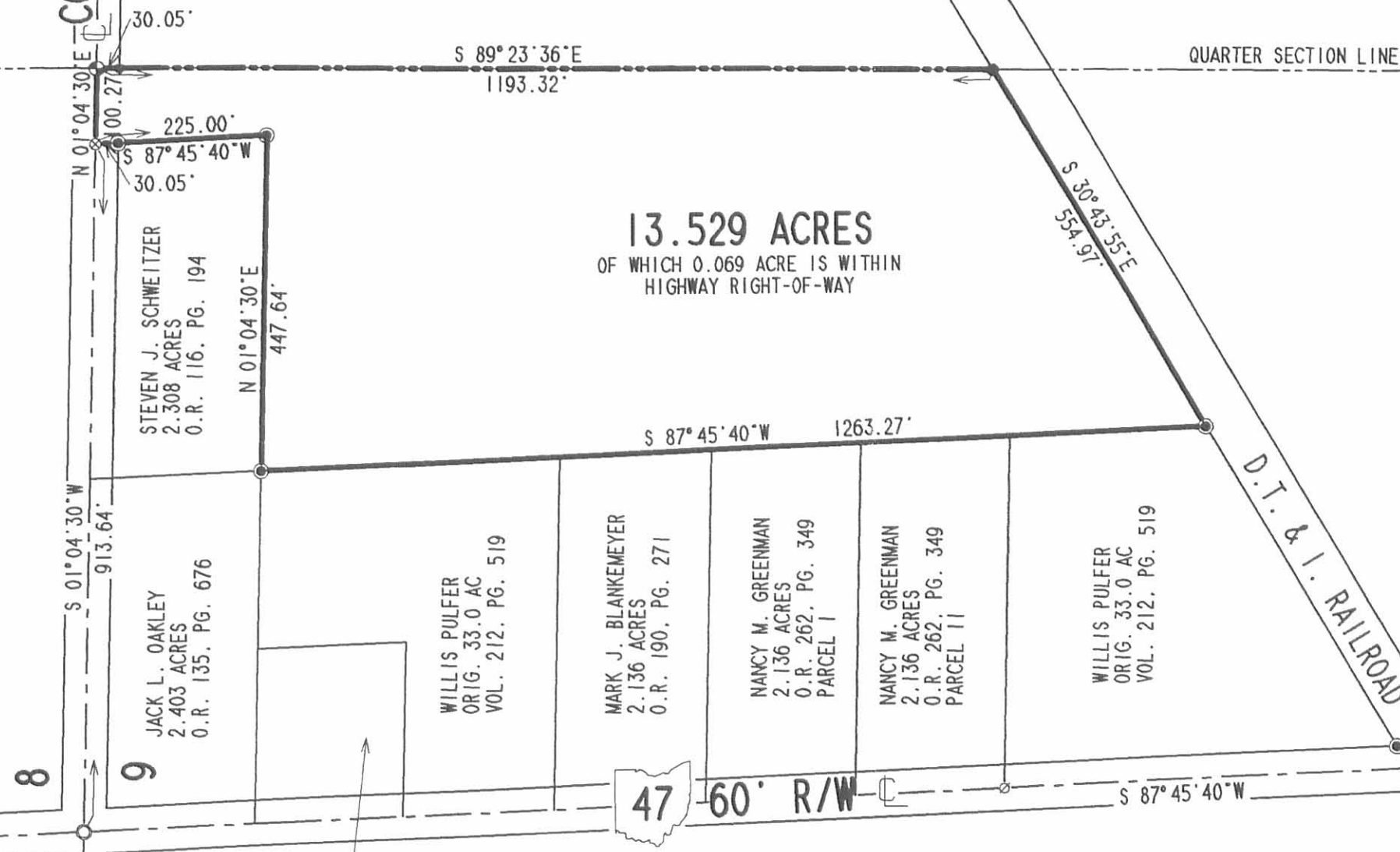

LEGEND

- 5/8" IRON ROD FOUND
- 5/8" IRON ROD SET
- ⊙ 1/2" IRON ROD FOUND
- ⊘ P.K. NAIL SET
- P.K. NAIL FOUND
- ⊕ RAILROAD SPIKE SET
- ⊗ RAILROAD SPIKE FOUND

13.529 ACRES
OF WHICH 0.069 ACRE IS WITHIN
HIGHWAY RIGHT-OF-WAY

SURVEY OF 13.529 ACRES OUT OF THE
WILLIS PULFER
ORIGINAL 33.0 ACRE TRACT
VOLUME 212, PAGE 519
SECTION 9, TOWN 1, RANGE 8
PLEASANT TOWNSHIP
LOGAN COUNTY, OHIO

SURVEYED BY:

JEFFREY I. LEE
PROFESSIONAL SURVEYOR 6359
JANUARY 11, 1995
REV. MARCH 15, 1996



COPYRIGHT 1996 BY:
LEE SURVEYING & MAPPING CO., INC.
143 East Columbus Avenue
BELLEFONTAINE, OHIO 43311
(513) 593-7335

ORIGINAL STAMP IN GREEN 270 WPULFER2

L-1480-3

2 WORKING DAYS
BEFORE YOU DIG
CALL TOLL FREE 800-362-2764
OHIO UTILITIES PROTECTION SERVICE.

INDEXED ON MAP
7742 2P

Received 3-15-88

OK 3+17-38 C.R

Lee Surveying and Mapping Co.



Farm Surveys • Lot Surveys • Topography • Subdivisions • Construction Layout

855 EAST SANDUSKY AVENUE
BELLEFONTAINE, OHIO 43311

(513) 593-5780

CLAYTON M. LEE, P.S.
JEFFREY I. LEE, P.S.

WILLIS PULFER (TRACT I)

Lying in the southwest quarter of Section 9, T-1, R-8, Pleasant Township, Logan County, Ohio.

Being a part of that land in the name of Willis Pulfer as deeded and described in Volume 212, Page 519 of the Logan County Records of Deeds and particularly a part of that land lying north of State Route 47 and east of County Road 23 and being better described as follows:

Beginning at a railroad spike set on the center-line of County Road 23, a distance of 466.00 feet, northerly, with said center-line, from the center-line of State Route 47.

THENCE, with the said center-line of County Road 23, N 1°-04'-30" E, a distance of 447.64 feet to a railroad spike (set).

THENCE, parallel to State Route 47, N 87°-45'-40" E, a distance of 225.00 feet to a 1/2" iron rod (set).

THENCE, parallel to County Road 23, S 1°-04'-30" W, a distance of 447.64 feet to a 1/2" iron rod.

THENCE, S 87°-45'-40" W, a distance of 225.00 feet to the point of beginning.

Containing 2.308 acres.

This description prepared from an actual field survey.

Basis for bearings: Center-line of County Road 23 = N 1°-04'-30" E.

Prepared by:

Clayton M. Lee

Clayton M. Lee
Registered Professional Surveyor No. 6181
March 8, 1988

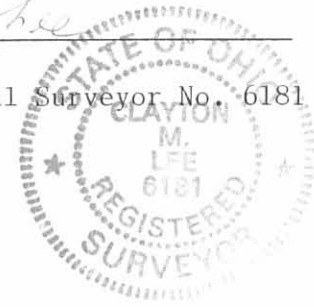

ORIGINAL STATE

INDEXED ON MAP
7742 3D-1

L-1480-3-1

Received 3-15-88 CE 3-17-88 CL

Lee Surveying and Mapping Co.



Farm Surveys • Lot Surveys • Topography • Subdivisions • Construction Layout

855 EAST SANDUSKY AVENUE
BELLEFONTAINE, OHIO 43311

(513) 593-5780

CLAYTON M. LEE, P.S.
JEFFREY I. LEE, P.S.

WLLIS PULFER (TRACT 2)

Lying in the southwest quarter of Section 9, T-1, R-8, Pleasant Township, Logan County, Ohio.

Being a part of that land in the name of Willis Pulfer as deeded and described in Volume 212, Page 519 of the Logan County Records of Deeds and particularly a part of that land lying north of State Route 47 and east of County Road 23 and being better described as follows:

Beginning at a 'PK' nail found at the intersection of the center-lines of County Road 23 and State Route 47.

THENCE, with the said center-line of County Road 23, N 1°-04'-30" E, a distance of 466.00 feet to a railroad spike (set).

THENCE, parallel to State Route 47, N 87°-45'-40" E, a distance of 225.00 feet to a 1/2" iron rod.

THENCE, parallel to County Road 23, S 1°-04'-30" W, a distance of 466.00 feet to a "PK" nail set on the center-line of State Route 47, passing through a 1/2" iron rod set on the north right-of-way line at 435.95 feet.

THENCE, with the center-line of said State Route 47, S 87°-45'-40" W, a distance of 225.00 feet to the point of beginning.

Containing 2.403 acres.

This description prepared from an actual field survey.

Basis for bearings: Center-line of State Route 47 = S 87°-45'-40" W.

Prepared by:

Clayton M. Lee
Registered Professional Surveyor No. 6181
March 8, 1988

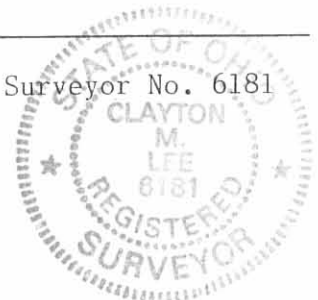

ORIGINAL STAMP IN GREEN

INDEXED ON MAP
7742 3D-2

Received 3-15-88

OK 3-17-88

Lee Surveying and Mapping Co.



Farm Surveys • Lot Surveys • Topography • Subdivisions • Construction Layout

855 EAST SANDUSKY AVENUE
BELLEFONTAINE, OHIO 43311

(513) 593-5780

CLAYTON M. LEE, P.S.
JEFFREY I. LEE, P.S.

WILLIS PULFER (TRACT 3)

Lying in the southwest quarter of Section 9, T-1, R-8, Pleasant Township, Logan County, Ohio.

Being a part of that land in the name of Willis Pulfer as deeded and described in Volume 212, Page 519 of the Logan County Records of Deeds and particularly a part of that land lying north of State Route 47 and east of County Road 23 and being better described as follows:

Beginning at a 'PK' nail set on the center-line of State Route 47, a distance of 225.00 feet, easterly, with said center-line, from the center-line of County Road 23.

THENCE, parallel to County Road 23, N 1°-04'-30" E, a distance of 466.00 feet to a 1/2" iron rod, passing through a 1/2" iron rod set on the north right-of-way line at 30.05 feet.

THENCE, parallel to State Route 47, N 87°-45'-40" E, a distance of 200.00 feet to a 1/2" iron rod.

THENCE, parallel to County Road 23, S 1°-04'-30" W, a distance of 466.00 feet to a 'PK' nail set on the center-line of State Route 47, passing through a 1/2" iron rod set on the said north right-of-way line of the said State Route 47 at 435.95 feet.

THENCE, with the center-line of State Route 47, S 87°-45'-40" W, a distance of 200.00 feet to the point of beginning.

Containing 2.136 acres.

This description prepared from an actual field survey.

Basis for bearings: Center-line of State Route 47 = S 87°-45'-40" W.

Prepared by:

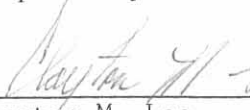
Clayton M. Lee
Registered Professional Surveyor No. 6188
March 9, 1988

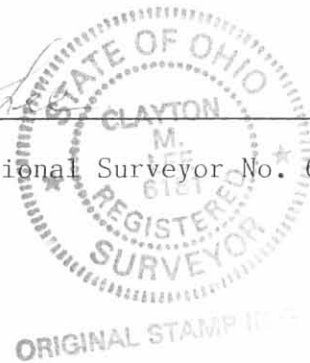

INDEXED ON MAP
7742 3D-3

Received 3-15-88

OK 3-17-88 C-R

Lee Surveying and Mapping Co.



Farm Surveys • Lot Surveys • Topography • Subdivisions • Construction Layout

855 EAST SANDUSKY AVENUE
BELLEFONTAINE, OHIO 43311

(513) 593-5780

CLAYTON M. LEE, P.S.
JEFFREY I. LEE, P.S.

WILLIS PULFER (TRACT 4)

Lying in the southwest quarter of Section 9, T-1, R-8, Pleasant Township, Logan County, Ohio.

Being a part of that land in the name of Willis Pulfer as deeded and described in Volume 212, Page 519 of the Logan County Records of Deeds and particularly a part of that land lying north of State Route 47 and east of County Road 23 and being better described as follows:

Beginning at a 'PK' nail set on the center-line of State Route 47, a distance of 425.00 feet, easterly, with said center-line, from the center-line of County Road 23.

THENCE, parallel to County Road 23, N 1°-04'-30" E, a distance of 466.00 feet to a 1/2" iron rod, passing through a 1/2" iron rod set on the north right-of-way line at 30.05 feet.

THENCE, parallel to State Route 47, N 87°-45'-40" E, a distance of 200.00 feet to a 1/2" iron rod.

THENCE, parallel to County Road 23, S 1°-04'-30" W, a distance of 466.00 feet to a 'PK' nail set on the center-line of State Route 47, passing through a 1/2" iron rod set on the said north right-of-way line of the said State Route 47 at 435.95 feet.

THENCE, with the center-line of State Route 47, S 87°-45'-40" W, a distance of 200.00 feet to the point of beginning.

Containing 2.136 acres.

This description prepared from an actual field survey.
Basis for bearings: Center-line of State Route 47 = S 87°-45'-40" W.

Prepared by:

Clayton M. Lee
Registered Professional Surveyor No. 6188
March 9, 1988

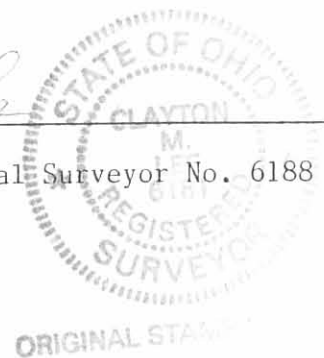

INDEXED ON MAP
7742 3D-4

L-1480-3-4

Lee Surveying and Mapping Co.



Farm Surveys • Lot Surveys • Topography • Subdivisions • Construction Layout

855 EAST SANDUSKY AVENUE
BELLEFONTAINE, OHIO 43311

(513) 593-5780

CLAYTON M. LEE, P.S.
JEFFREY I. LEE, P.S.

WILLIS PULFER (TRACT 5)

Lying in the southwest quarter of Section 9, T-1, R-8, Pleasant Township, Logan County, Ohio.

Being a part of that land in the name of Willis Pulfer as deeded and described in Volume 212, Page 519 of the Logan County Records of Deeds and particularly a part of that land lying north of State Route 47 and east of County Road 23 and being better described as follows:

Beginning at a 'PK' nail set on the center-line of State Route 47, a distance of 625.00 feet, easterly, with said center-line, from the center-line of County Road 23.

THENCE, parallel to County Road 23, N 1°-04'-30" E, a distance of 466.00 feet to a 1/2" iron rod, passing through a 1/2" iron rod set on the north right-of-way line at 30.05 feet.

THENCE, parallel to State Route 47, N 87°-45'-40" E, a distance of 200.00 feet to a 1/2" iron rod.

THENCE, parallel to County Road 23, S 1°-04'-30" W, a distance of 466.00 feet to a 'PK' nail set on the center-line of State Route 47, passing through a 1/2" iron rod set on the said north right-of-way line of the said State Route 47 at 435.95 feet.

THENCE, with the center-line of State Route 47, S 87°-45'-40" W, a distance of 200.00 feet to the point of beginning.

Containing 2.136 acres.

This description prepared from an actual field survey.
Basis for bearings: Center-line of State Route 47 = S 87°-45'-40" W.

Prepared by:

Clayton M. Lee
Registered Professional Surveyor No. 6188
March 9, 1988

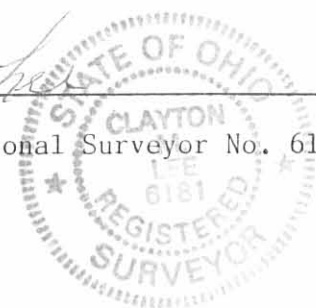

ORIGINAL STAMP

INDEXED ON MAP
7742 3D-5

L-1480-3-5

Lee Surveying and Mapping Co.



Farm Surveys • Lot Surveys • Topography • Subdivisions • Construction Layout

855 EAST SANDUSKY AVENUE
BELLEFONTAINE, OHIO 43311

(513) 593-5780

CLAYTON M. LEE, P.S.
JEFFREY I. LEE, P.S.

WILLIS PULFER (TRACT 6)

Lying in the southwest quarter of Section 9, T-1, R-8, Pleasant Township, Logan County, Ohio.

Being a part of that land in the name of Willis Pulfer as deeded and described in Volume 212, Page 519 of the Logan County Records of Deeds and particularly a part of that land lying north of State Route 47 and east of County Road 23 and being better described as follows:

Beginning at a 'PK' nail set on the center-line of State Route 47, a distance of 825.00 feet, easterly, with said center-line, from the center-line of County Road 23.

THENCE, parallel to County Road 23, N 1°-04'-30" E, a distance of 466.00 feet to a ½" iron rod, passing through a ½" iron rod set on the north right-of-way line at 30.05 feet.

THENCE, parallel to State Route 47, N 87°-45'-40" E, a distance of 200.00 feet to a ½" iron rod.

THENCE, parallel to County Road 23, S 1°-04'-30" W, a distance of 466.00 feet to a 'PK' nail set on the center-line of State Route 47, passing through a ½" iron rod set on the said north right-of-way line of the said State Route 47 at 435.95 feet.

THENCE, with the center-line of State Route 47, S 87°-45'-40" W, a distance of 200.00 feet to the point of beginning.

Containing 2.136 acres.

This description prepared from an actual field survey.

Basis for bearings: Center-line of State Route 47 = S 87°-45'-40" W.

Prepared by:

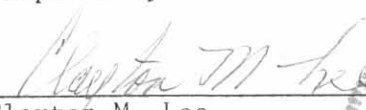
Clayton M. Lee
Registered Professional Surveyor No. 6188
March 9, 1988

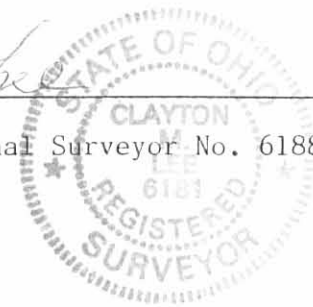

ORIGINAL STAMP IN CLAYTON

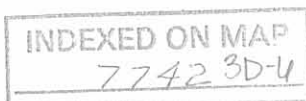

Lee Surveying and Mapping Co.



Farm Surveys • Lot Surveys • Topography • Subdivisions • Construction Layout

855 EAST SANDUSKY AVENUE
BELLEFONTAINE, OHIO 43311

(513) 593-5780

CLAYTON M. LEE, P.S.
JEFFREY I. LEE, P.S.

WILLIS PULFER (TRACT 7)

Lying in the southwest quarter of Section 9, T-1, R-8, Pleasant Township, Logan County, Ohio.

Being a part of that land in the name of Willis Pulfer as deeded and described in Volume 212, Page 519 of the Logan County Records of Deeds and particularly a part of that land lying north of State Route 47 and east of County Road 23 and being better described as follows:

Beginning at a 'PK' nail set on the center-line of State Route 47, a distance of 1025.00 feet, easterly, with said center-line, from the center-line of County Road 23.

THENCE, parallel to County Road 23, N 1°-04'-30" E, a distance of 466.00 feet to a 1/2" iron rod, passing through a 1/2" iron rod set on the north right-of-way line at 30.05 feet.

THENCE, parallel to State Route 47, N 87°-45'-40" E, a distance of 200.00 feet to a 1/2" iron rod.

THENCE, parallel to County Road 23, S 1°-04'-30" W, a distance of 466.00 feet to a 'PK' nail set on the center-line of State Route 47, passing through a 1/2" iron rod set on the said north right-of-way line of the said State Route 47 at 435.95 feet.

THENCE, with the center-line of State Route 47, S 87°-45'-40" W, a distance of 200.00 feet to the point of beginning.

Containing 2.136 acres.

This description prepared from an actual field survey.

Basis for bearings: Center-line of State Route 47 = S 87°-45'-40" W.

Prepared by:

Clayton M. Lee

Clayton M. Lee
Registered Professional Surveyor No. 6188
March 9, 1988



INDEXED ON MAP
77423D-7

Lee Surveying and Mapping Co.



Farm Surveys • Lot Surveys • Topography • Subdivisions • Construction Layout

855 EAST SANDUSKY AVENUE
BELLEFONTAINE, OHIO 43311

(513) 593-5780

CLAYTON M. LEE, P.S.
JEFFREY I. LEE, P.S.

WILLIS PULFER (TRACT 8)

Lying in the southwest quarter of Section 9, T-1, R-8, Pleasant Township, Logan County, Ohio.

Being a part of that land in the name of Willis Pulfer as deeded and described in Volume 212, Page 519 of the Logan County Records of Deeds and particularly a part of that land lying north of State Route 47 and east of County Road 23 and being better described as follows:

Beginning at a 'PK' nail set on the center-line of State Route 47, a distance of 1225.00 feet, easterly, with said center-line, from the center-line of County Road 23.

THENCE, parallel to County Road 23, N 1°-04'-30" E, a distance of 466.00 feet to a 1/2" iron rod, passing through a 1/2" iron rod set on the north right-of-way line at 30.05 feet.

THENCE, parallel to State Route 47, N 87°-45'-40" E, a distance of 200.00 feet to a 1/2" iron rod.

THENCE, parallel to County Road 23, S 1°-04'-30" W, a distance of 466.00 feet to a 'PK' nail set on the center-line of State Route 47, passing through a 1/2" iron rod set on the said north right-of-way line of the said State Route 47 at 435.95 feet.

THENCE, with the center-line of State Route 47, S 87°-45'-40" W, a distance of 200.00 feet to the point of beginning.

Containing 2.136 acres.

This description prepared from an actual field survey.

Basis for bearings: Center-line of State Route 47 = S 87°-45'-40" W.

Prepared by:

Clayton M. Lee
Registered Professional Surveyor No. 6188
March 9, 1988

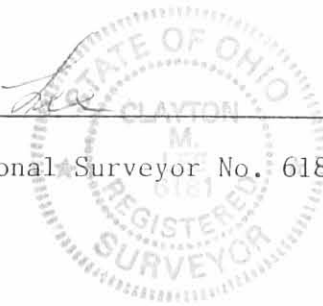

ORIGINAL STAMP IN GREEN

INDEXED ON MAP
7742 3D-B

Received 3-15-88

Lee Surveying and Mapping Co.



Farm Surveys • Lot Surveys • Topography • Subdivisions • Construction Layout

855 EAST SANDUSKY AVENUE
BELLEFONTAINE, OHIO 43311

(513) 593-5780

CLAYTON M. LEE, P.S.
JEFFREY I. LEE, P.S.

WILLIS PULFER (TRACT 9)

Lying in the southwest quarter of Section 9, T-1, R-8, Pleasant Township, Logan County, Ohio.

Being a part of that land in the name of Willis Pulfer as deeded and described in Volume 212, Page 519 of the Logan County Records of Deeds and particularly a part of that land lying north of State Route 47 and east of County Road 23 and being better described as follows:

Beginning at a 'PK' nail set on the center-line of State route 47, a distance of 1425.00 feet, easterly, with said center-line, from the center-line of County Road 23.

THENCE, parallel to County Road 23. N 1°-04'-30" E, a distance of 466.00 feet to a 1/2" iron rod, passing through a 1/2" iron rod set on the north right-of-way line at 30.05 feet.

THENCE, parallel to State Route 47, N 87°-45'-40" E, a distance of 63.27 feet to a 1/2" iron rod set on the west right-of-way line of the D.T. & I. Railroad.

THENCE, with said railroad right-of-way line, S 30°-43'-55" E, a distance of 529.34 feet to a 'PK' nail set on the center-line of State Route 47, passing through a 1/2" iron rod set on the north right-of-way line of State Route 47 at 495.21 feet.

THENCE, with the said center-line of State route 47, S 87°-45'-40" W, a distance of 342.73 feet to the point of beginning.

Containing 2.168 acres.

This description prepared from an actual field survey.

Basis for bearings: Center-line of Sate Route 47 = S 87°-45'-40" W,

Prepared by:

Clayton M. Lee

Clayton M. Lee
Registered professional Surveyor No. 6181
March 9, 1988

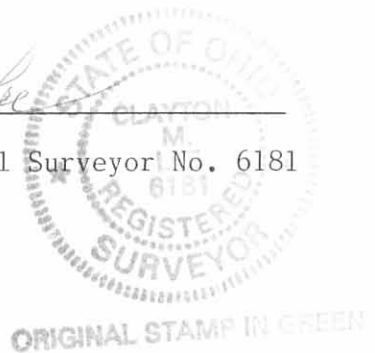

INDEXED ON MAP
77-423D-91



Lee Surveying and Mapping Co.



Farm Surveys • Lot Surveys • Topography • Subdivisions • Construction Layout

143 EAST COLUMBUS AVENUE
BELLEFONTAINE, OHIO 43311

(513) 593-7335

JEFFREY I. LEE, P.S.

PULFER (1.056 ACRE)

Lying in Section 9, Town 1, Range 8, Pleasant Township, Logan County, Ohio.

Being out of the Willis Pulfer original 118.86 acre tract as deeded and described in Volume 212, Page 519 of the Logan County Records of Deeds and being more particularly described as follows:

Beginning at a PK nail set on the center-line of State Route 47, N 87°-45'-40" E, a distance of 225.00 feet from a PK nail found at the intersection of center-lines of State Route 47 and Township Road 23.

THENCE, with the east line of the Jack Oakley 2.403 acre tract (O.R. 135, Pg. 676, N 1°-04'-30" E, a distance of 230.05 feet to a 5/8 inch iron rod set.

THENCE, N 87°-45'-40" E, a distance of 200.00 feet to a 5/8 inch iron rod set.

THENCE, S 1°-04'-30" W, a distance of 230.05 feet to a PK nail set.

THENCE, with the center-line of State Route 47, S 87°-45'-40" W, a distance of 200.00 feet to the point of beginning.

Containing 1.056 acre of which 0.138 acre is within the highway right-of-way.

The basis for bearings is based upon the center-line of State Route 47 being S 87°-45'-40" W, and all other bearings are from angles and distances measured in a field survey by Lee Surveying and Mapping Company on August 6, 1992.

Description prepared by:

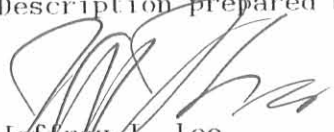
Jeffrey I. Lee
Professional Surveyor 6359
August 12, 1992



J. 1480

ORIGINAL STAMP IN GREEN

INDEXED ON MAP
7742 4D

WILLIS PULFER
ORIG. 118.86 AC.
VOL. 212. PG. 519

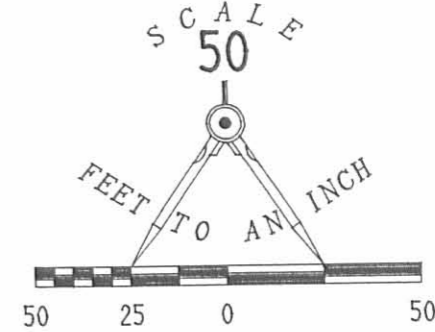

JACK OAKLEY
2.403 AC.
O.R. 135. PG. 676

1.056 ACRES
OF WHICH 0.138 ACRE IS WITHIN
THE HIGHWAY RIGHT-OF-WAY

LEGEND

- ⊗ PK NAIL SET
- 5/8" I. ROD SET
- 1/2" I. ROD FOUND
- PK NAIL FOUND

REFERENCES:
O.D.O.T. RIGHT-OF-WAY PLANS
FOR STATE ROUTE 47

LOGAN COUNTY ENGINEER'S
RECORDS FOR COUNTY HIGHWAY 23

N 01° 04' 30" E
TOWNSHIP ROAD 23 (50')



S 87° 45' 40" W
225.00'

N 01° 04' 30" E
230.05'

N 87° 45' 40" E
200.00'

S 01° 04' 30" W
230.05'

200.00'
S 87° 45' 40" W

60'

SURVEY OF 1.056 ACRES OUT OF THE
WILLIS PULFER
ORIGINAL 118.86 ACRE TRACT
VOLUME 212. PAGE 519
SECTION 9. TOWN 1. RANGE 8
PLEASANT TOWNSHIP
LOGAN COUNTY. OHIO

INDEXED ON MAP
7742 4P



ORIGINAL STAMP IN GREEN

SURVEYED BY:
Jeffrey I. Lee
JEFFREY I. LEE
PROFESSIONAL SURVEYOR 6359
AUGUST 6, 1992

LEE SURVEYING & MAPPING CO.
143 East Columbus Avenue
BELLEFONTAINE, OHIO 43311
(513) 593-7335

REC'D 2-11-97 *my ok*



Lee Surveying and Mapping Co., Inc.



Farm Surveys • Lot Surveys • Topography • Subdivisions • Construction Layout

117 NORTH MADRIVER STREET
BELLEFONTAINE, OHIO 43311

(937) 593-7335
FAX (937) 593-7444

WILLIS PULFER 1.082 ACRES

Lying in Section 9, Town 1, Range 8, Pleasant Township, Logan County, Ohio.

Being out of the Willis Pulfer original 118.86 acre tract as deeded and described in Volume 212, Page 519 of the Logan County Records of Deeds and being more particularly described as follows:

Beginning at a PK nail set at the intersection of center-lines of State Route 47 and Township Road 23.

THENCE, with the center-line of State Route 47, N 87°-45'-40" E, a distance of 225.00 feet to a PK nail set.

THENCE, with the east line of Jack Oakley 2.403 acre tract (O.R. 135, Pg. 676), N 1°-04'-30" E, a distance of 230.05 feet to a 5/8 inch iron rod set at the TRUE POINT OF BEGINNING.

THENCE, with east line of the said 2.403 acre tract, N 1°-04'-30" E, a distance of 235.95 feet to a 1/2 inch iron rod found.

THENCE, N 87°-45'-40" E, a distance of 200.00 feet to a 1/2 inch iron rod found.

THENCE, S 1°-04'-30" W, a distance of 235.95 feet to a 5/8 inch iron rod set.

THENCE, S 87°-45'-40" W, a distance of 200.00 feet to the point of beginning.

Containing 1.082 acre.

The basis for bearing is based upon the center-line of State Route 47 being N 87°-45'-40" E, and all other bearings are from angles and distances measured in a field survey by Lee Surveying and Mapping Company on August 6, 1992.

Description prepared by:

William K. Bruce
Professional Surveyor No. 7437
February 3, 1993
Revised February 10, 1997



ORIGINAL STAMP IN GREEN

L 1480

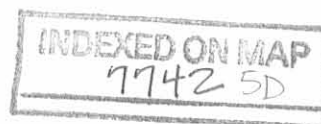

WILLIS PULFER
ORIG. 118.86 AC.
VOL. 212. PG. 519

TOWNSHIP ROAD 23 (50')

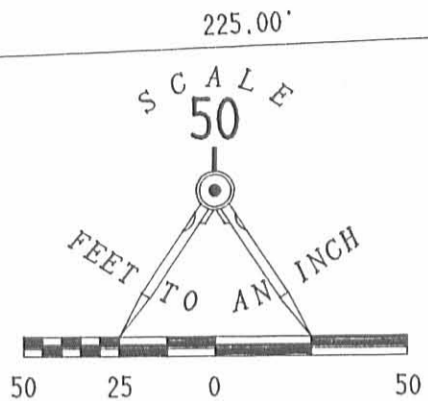

LEGEND

- ∅ PK NAIL SET
- 5/8" I. ROD SET
- 1/2" I. ROD FOUND
- PK NAIL FOUND

REFERENCES:
O.D.O.T. RIGHT-OF-WAY PLANS
FOR STATE ROUTE 47

LOGAN COUNTY ENGINEER'S
RECORDS FOR COUNTY HIGHWAY 23

JACK OAKLEY
2.403 AC.
O.R. 135. PG. 676

N 87° 45' 40" E
200.00'

1.082 ACRES

N 01° 04' 30" E
235.95'

S 01° 04' 30" W
235.95'

200.00'
S 87° 45' 40" W

1.056 ACRES
OF WHICH 0.138 ACRE IS WITHIN
THE HIGHWAY RIGHT-OF-WAY

N 01° 04' 30" E
230.05'

S 01° 04' 30" W
230.05'

200.00'
S 87° 45' 40" W

60.0'



SURVEY OF 1.080 ACRES OUT OF THE
WILLIS PULFER
ORIGINAL 118.86 ACRE TRACT
VOLUME 212. PAGE 519
SECTION 9. TOWN 1. RANGE 8
PLEASANT TOWNSHIP
LOGAN COUNTY. OHIO

SURVEYED BY:

William K. Bruce
WILLIAM K. BRUCE
PROFESSIONAL SURVEYOR 7437
AUGUST 6, 1992

LEE SURVEYING & MAPPING CO.
143 East Columbus Avenue
BELLEFONTAINE, OHIO 43311
(513) 593-7335

